

Precision Modules PSK

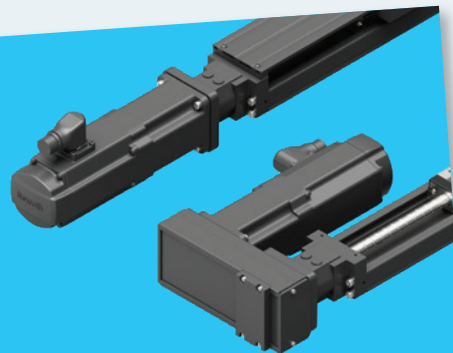
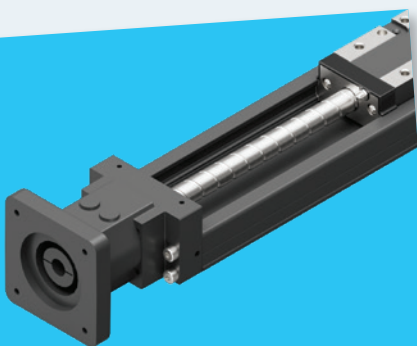

Identification system for short product names

Short product name	Example:	PSK	-	050	-	NN	-	2
System	=	P		recision module				
Guideway	=			Integrated ball rail s ystem				
Drive	=			Ball screw assembly (K)				
Size				050 / 060 / 090				
Version	=			Standard version (N)				
Generation	=			Product generation 2				

Changes compared to generation 1

- PSK 040 Gen. 2 discontinued
- Two accuracy classes
- Four lubrication versions
- Improved technical data
- New Rexroth ball screw assembly for PSK-050
- Smooth frame (side fastening discontinued)
- Chapter "Switching System"
- New motors

Contents

Product description	4
Load capacities and sizes	8
Structural design	10
Technical data	14
Technical data	14
Speed diagrams	20
Drive torque diagrams	20
Accuracy diagrams	22
Calculations	24
Calculation principles	24
Drive sizing	27
Calculation example	31
Configuration and ordering	34
PSK-050-NN-2	34
PSK-060-NN-2	36
PSK-090-NN-2	38
Dimension drawings	40
PSK without cover	40
PSK with cover plate	41
PSK with sealing strip	42
Motor attachments with flange and coupling	44
Motor attachments with belt side drive	45
Attachments and accessories	46
Motor attachment kits according to customer specification	46
IndraDyn S Synchronous Motor MSM	48
IndraDyn S Synchronous Motor MS2N	50
Switch mounting	52
Sensors	54
Extensions	56
Connectors	58
Passive distributor	60
Combination examples	64
Service and information	66
Operating conditions	66
Parameterization (commissioning)	67
Fastening	68
Lubrication and maintenance	69
Documentation	72
Ordering example for PSK-090	74
Inquiry/order form	75
Further information	76
Abbreviations	78

Product description

Rexroth precision modules are precise, ready-to-install linear systems with high performance features in compact dimensions. Rexroth provides a favorable price/performance ratio and fast delivery times.

Structural design

- ▶ Three sizes: PSK-050, -060, -090
- ▶ Smooth, compact and rigid precision steel profile with integrated Rexroth guideway geometry and machined reference edge
- ▶ Rexroth precision ball screw assembly with integrated seal (precision class)
- ▶ One or two steel carriages, in standard length or long versions
- ▶ Carriage with threads and pin holes
- ▶ Protection of the installation elements by selectable cover plate or sealing strip

Characteristic features

- ▶ Extremely stiff and highly precise miniature linear motion system
- ▶ Machined reference edge on frame facilitates rapid mounting and easy aligning
- ▶ Flexible usage options thanks to two accuracy classes:
 - N = normal class
 - P = precision class
- ▶ Four different lube versions:
 - Standard lubrication (LSS)
 - Preserved (LPG)
 - Prepared for connection to central lubrication systems for liquid grease (LCF)
 - International standard grease of clean room quality > 1 000 according to Fed. Std. 209 (LSC)

Attachments

- ▶ Motor attachments with flange and coupling or via a belt side drive
- ▶ Motor attachment kits according to customer specification
- ▶ Maintenance-free servo motors with optional brake and attached feedback
- ▶ Adjustable sensors over the entire travel range
- ▶ Aluminum profile mounting duct for sensors
- ▶ Various connection accessories

PSK without cover



PSK with cover plate

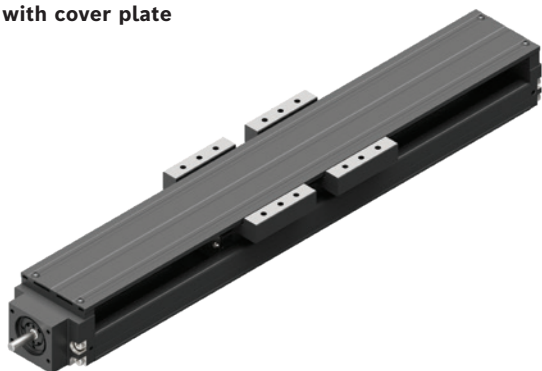

PSK with sealing strip

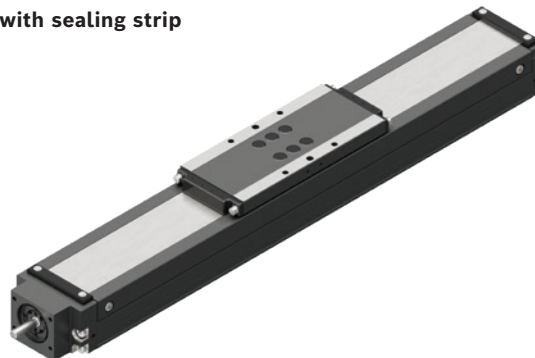

PSK with flange and coupling and mounted motor

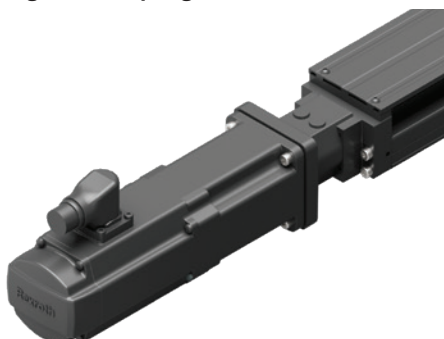

PSK with belt side drive and mounted motor

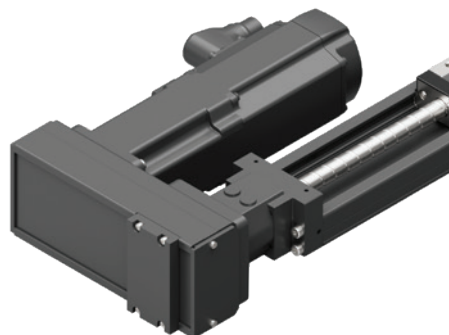

Product description

Notes on lubrication versions

LSS:

- ▶ Basic lubrication by Bosch Rexroth
- ▶ Dynalub 510 (PSK-060/-090) or Dynalub 520 (PSK-050) grease lubricant
- ▶ Relubrication using manual grease gun

LPG:

- ▶ Ball rail system and ball screw assembly coated with preservative only
- ▶ Relubrication using manual grease gun
- ▶ Basic lubrication by user required

LCF:

- ▶ Basic lubrication by Bosch Rexroth
- ▶ Prepared for connection to central liquid grease lubrication system (grade NLGI 00 as per DIN 51818)
- ▶ Dynalub 520 grease lubricant (grade NLGI 00)
- ▶ Optional connector available (straight or right-angled) for connecting to central lubrication systems
- ▶ Liquid grease lubrication via single-line piston distributor system only

LSC:

- ▶ Basic lubrication by Bosch Rexroth
- ▶ International standard grease of clean room quality > 1000 according to Fed. Std. 209
- ▶ Grease lubricant Tribol GR 100-2 PD or Tribol GR 100-00 PD
- ▶ Relubrication using manual grease gun

Form of delivery

Precision modules with ball rail system and ball screw assembly come fully assembled.

Motor attachment

If a motor and motor attachment are ordered, the components come installed as shown in the figure.

The position of the motor connector can also be selected. For more information on motor connector positions, see chapter "Configuration and Ordering".

When ordering motor attachments without motor, not all parts can be mounted.

Final assembly must then be carried out by the customer.

All required instructions and parameters for professional assembly are included.

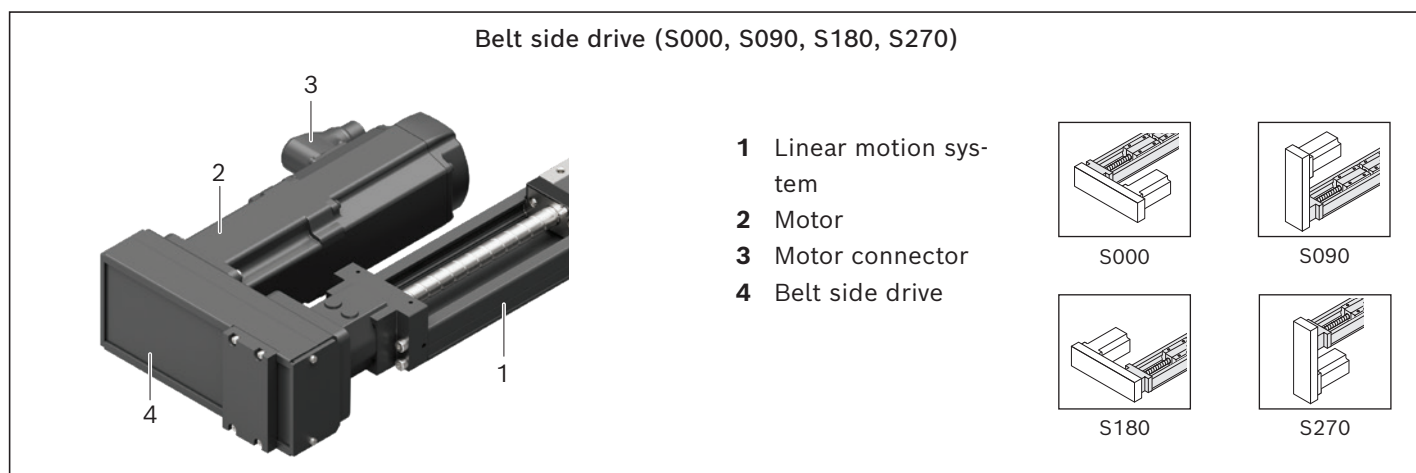
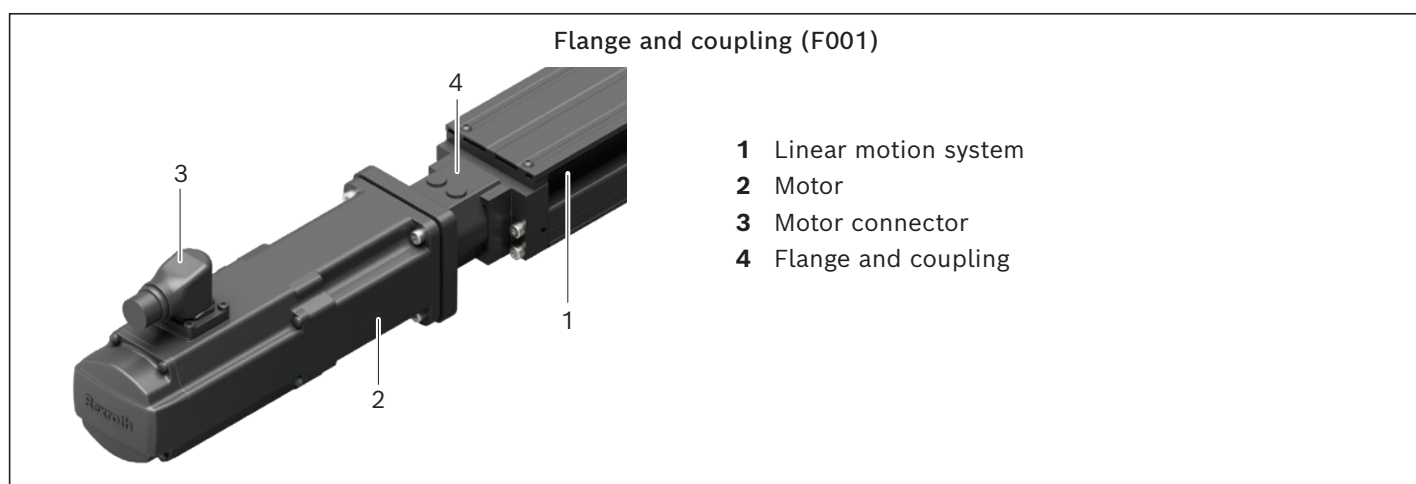

Available options

Cable duct, switching cam and sensor come unassembled.

Lubrication

Depending on the lubrication version, precision modules come with initial lubrication or preservation.

For more information on lubricants, see chapter "Lubrication and Maintenance".

Documentation

Each precision module is supplied with the accompanying documentation.

Load capacities and sizes

Suitable loads

(value on the basis of past experience)

For the desired service life, loads for F_m , F_{comb} should not exceed approx. 20% of the dynamic load capacity C_{100} . See chapter "Calculation Principles".

Do not exceed the technical data for the linear motion system.

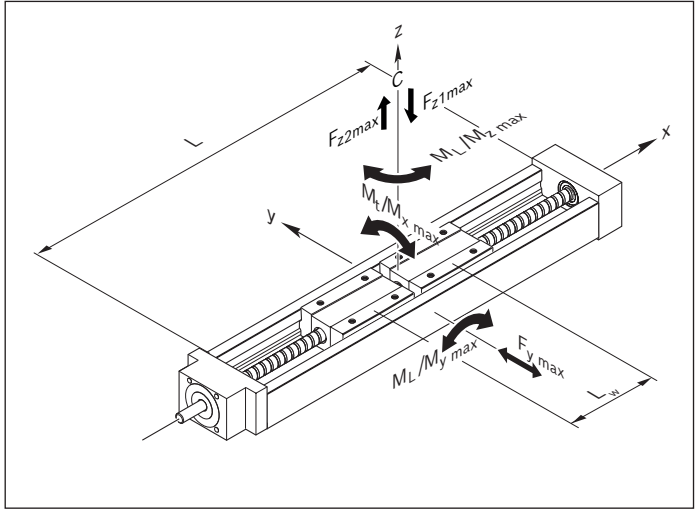

Overview of types with load capacities

Type	System	Guideway	Drive	Size	Carriage (TT)		Dynamic load capacities (N)	
					Version	Quantity	$C_{50}^{1)}$	$C_{100}^{2)}$
PSK	Precision module	Rail guide	Ball screw assembly	050	Long	1 TT	11 500	9 100
						2 TT	18 600	14 800
				060	Standard	1 TT	11 500	9 100
						2 TT	18 600	14 800
					Long	1 TT	14 500	11 500
						2 TT	23 540	18 700
				090	Standard	1 TT	27 500	21 800
						2 TT	44 600	35 400
					Long	1 TT	35 300	28 000
						2 TT	57 300	45 500

¹⁾ Dynamic load capacities and load moments are based on a 50 000 m travel as per DIN ISO 14728-1.

²⁾ Dynamic load capacities and load moments are based on a 100 000 m travel as per DIN ISO 14728-1.

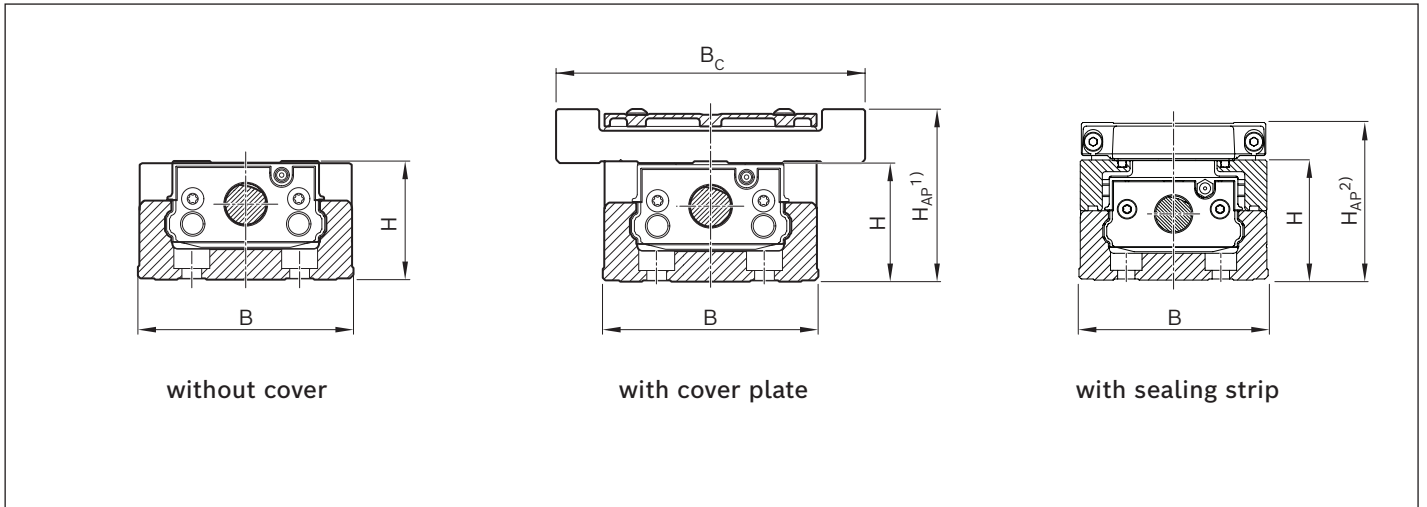
Dimensions (mm)

PSK	050	060	090
B	50	60	86
B_{AP}	62	86	112
H	26	33	46
H_{AP}¹⁾	40	48	68
H_{AP}²⁾	40	50	68
L	100 , 150, 200, 250, 300, 350, 400, 500, 600	150, 200, 250, 300, 400, 500, 600, 700, 800	340, 440, 540, 640, 740, 840, 940

Structural design

PSK without cover

- 1 Fixed bearing end block
- 2 Ball screw assembly
- 3 One or two carriages made of steel, standard or long
- 4 Frame with reference edge and integrated guide tracks
- 5 Floating bearing end block
- 6 Sensor

- 7 Cable duct
- 8 Switching cam

PSK with cover plate

- 9 Cover plate
- 10 One or two carriages, standard or long
- 11 Carriage plate, aluminum
- 12 Carriage plate guide unit, steel

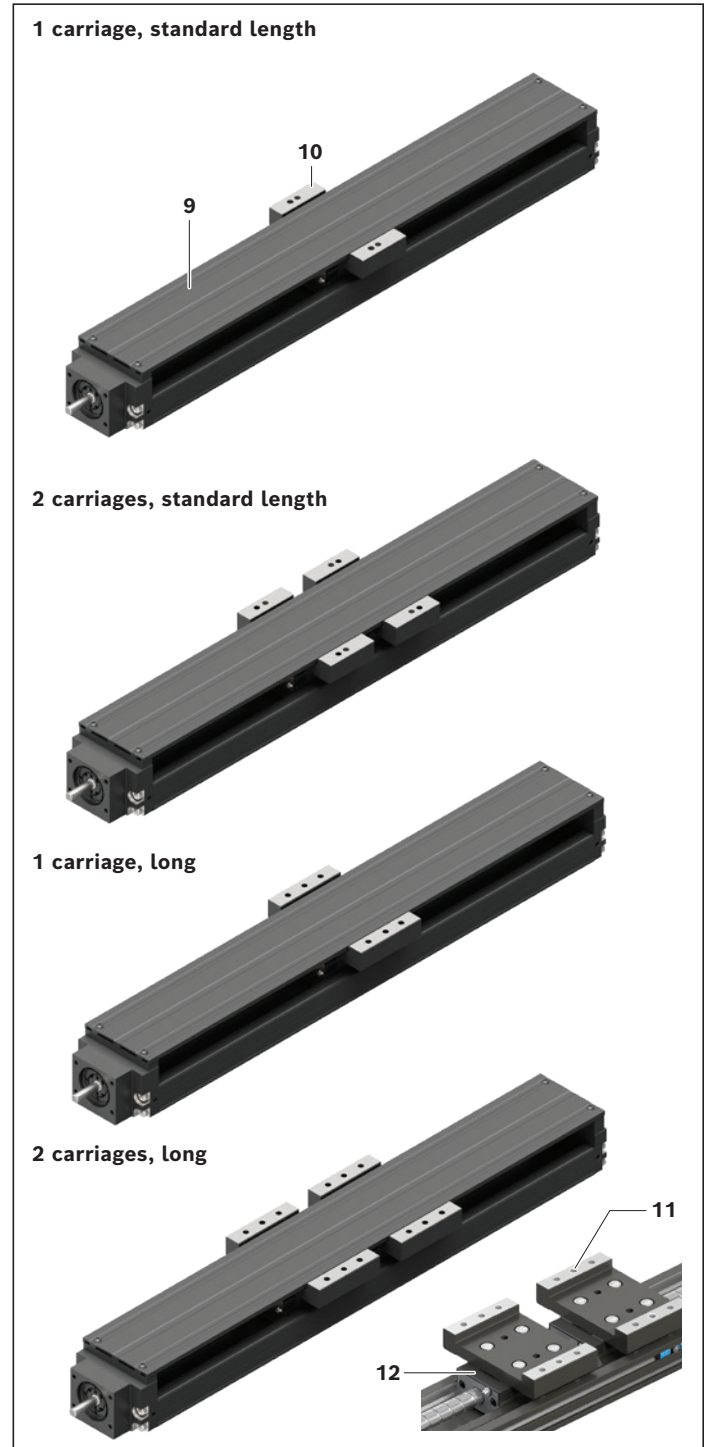
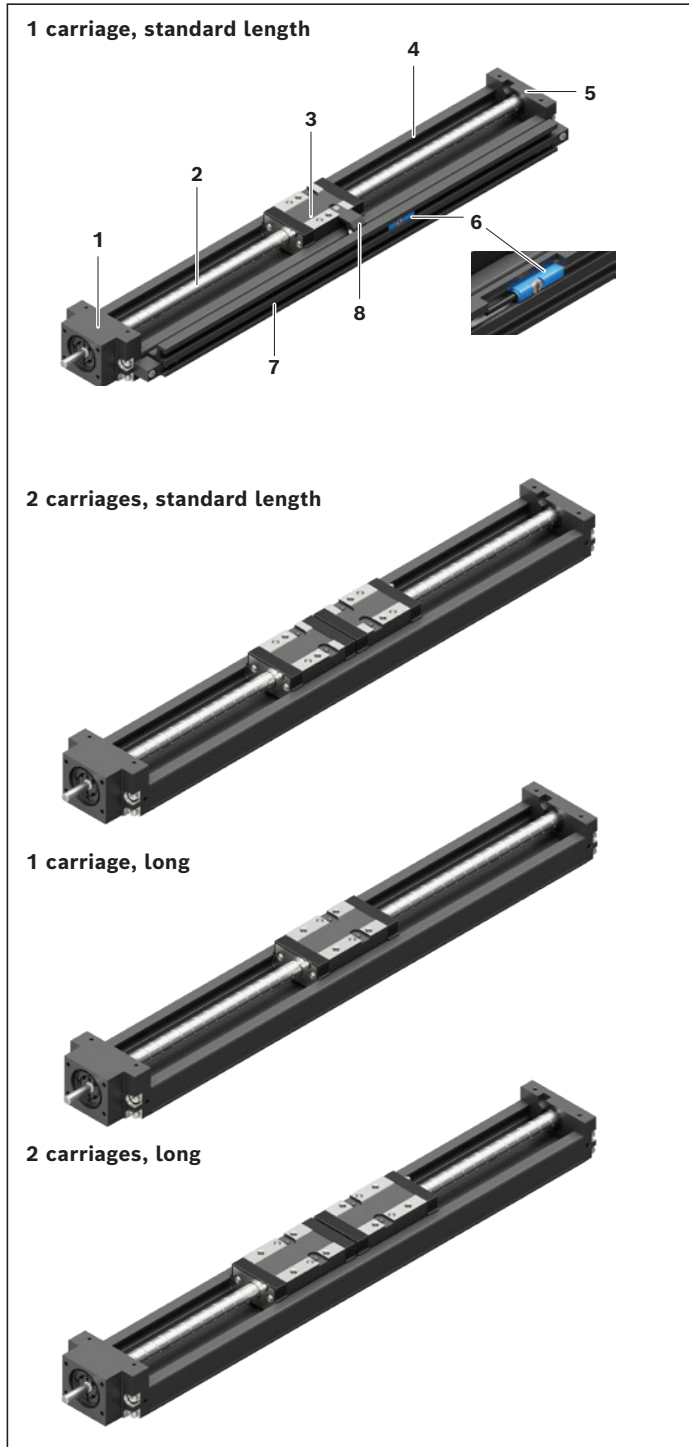

PSK with sealing strip

- 13** Sealing strip made of corrosion-resistant steel
- 14** One or two carriages, standard or long
- 15** Carriage plate, aluminum
- 16** Carriage plate guide unit, steel

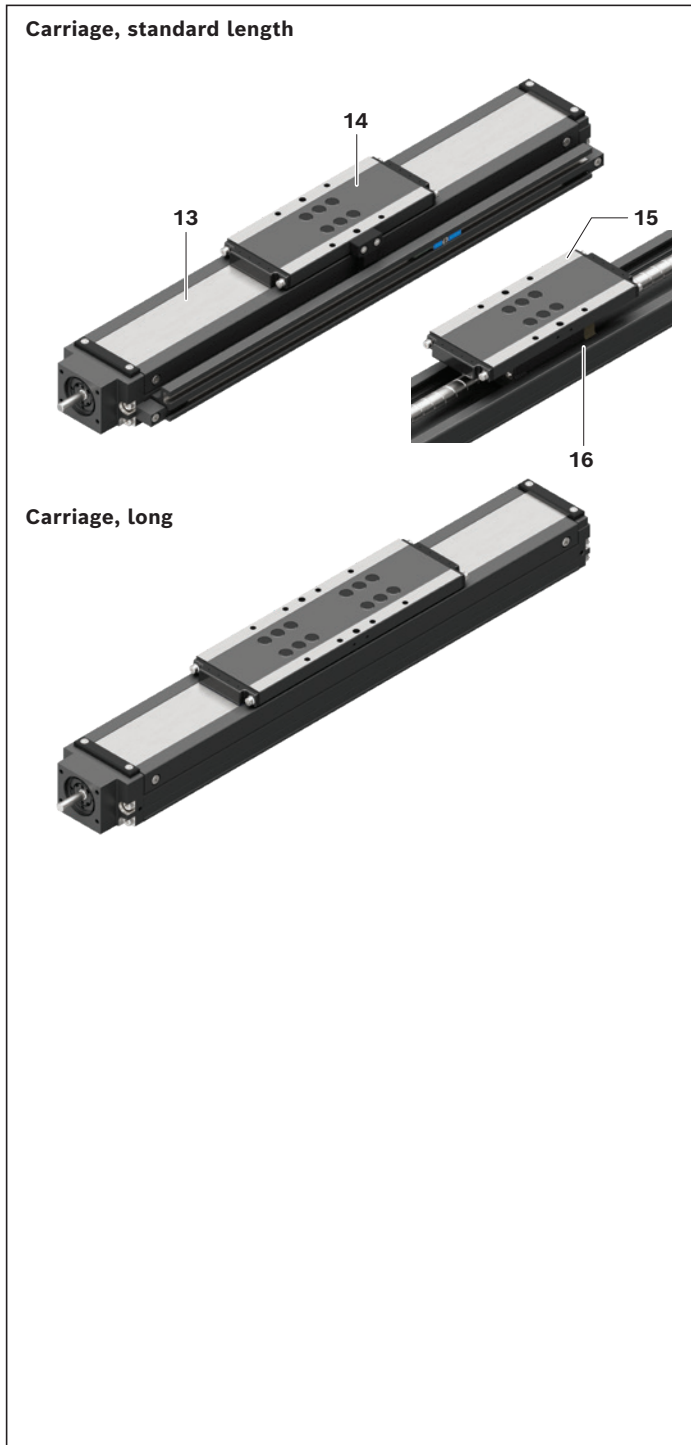

Structural design

Without motor attachment (screw journal version)

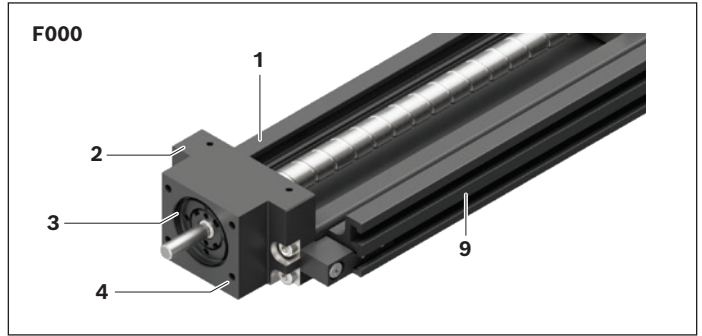

Motor attachment with flange and coupling

A motor can be attached to all precision modules by means of a motor flange and coupling.

Depending on its size, the motor is attached by a flange and coupling or a fixed bearing end block with integrated flange.

The flange serves to fasten the motor to the precision module and acts as a closed housing for the coupling. The coupling transmits the motor drive torque free of distortive stresses to the precision module's screw journal.

- 1 Frame
- 2 Fixed bearing end block
- 3 Motor alignment
- 4 Fastening thread
- 5 Fixed bearing end block with integrated motor flange
- 6 Coupling
- 7 Attached motor flange
- 8 Motor
- 9 Cable duct

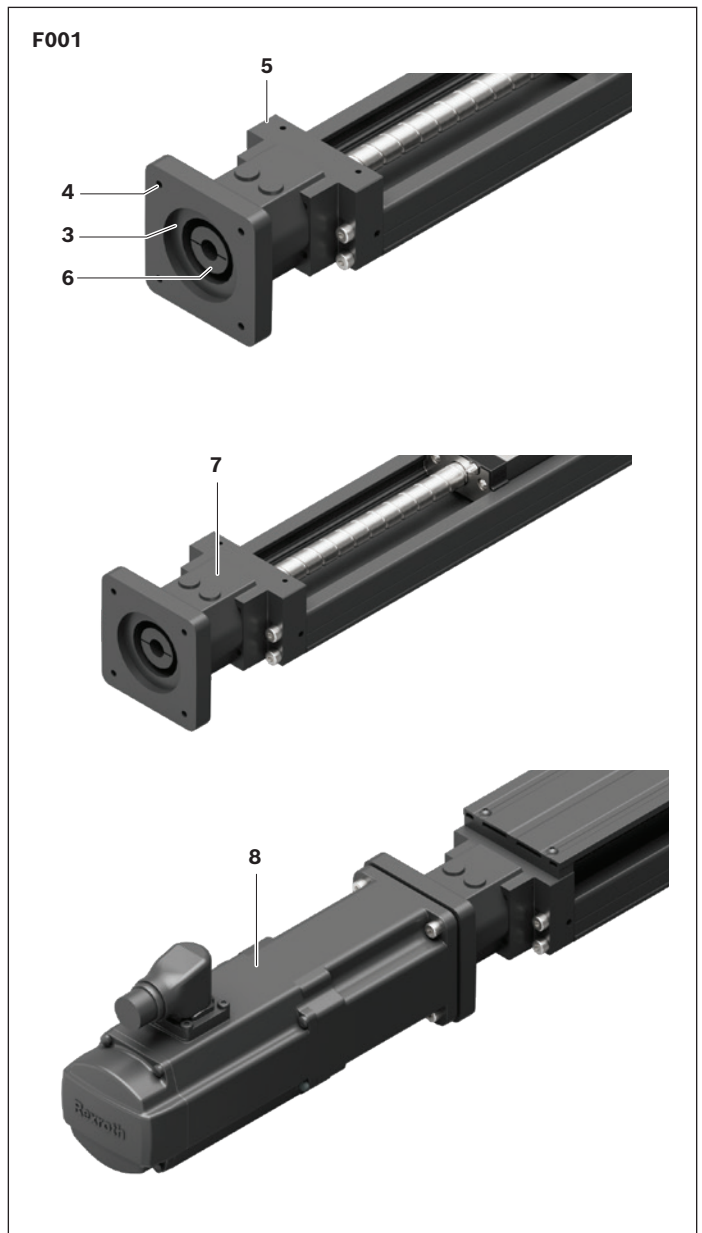

Motor attachment with belt side drive (S000–S270)

On the precision modules, the motor can be attached via a belt side drive.

This makes the overall length shorter than the motor attachment with flange and coupling.

The compact, closed housing serves as protection for the belt and as a motor bracket.

Various gear ratios are available:

- ▶ $i = 1 : 1$
- ▶ $i = 1 : 1.5$

The belt side drive can be mounted in four different directions:

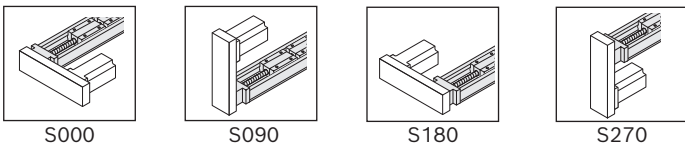

Components

- 1 Motor
- 2 Cover
- 3 Pulley housing made of anodized aluminum frame
- 4 Cover plate
- 5 Toothed belt
- 6 Screw journal with support bearing
- 7 Belt pulleys
- 8 Precision module

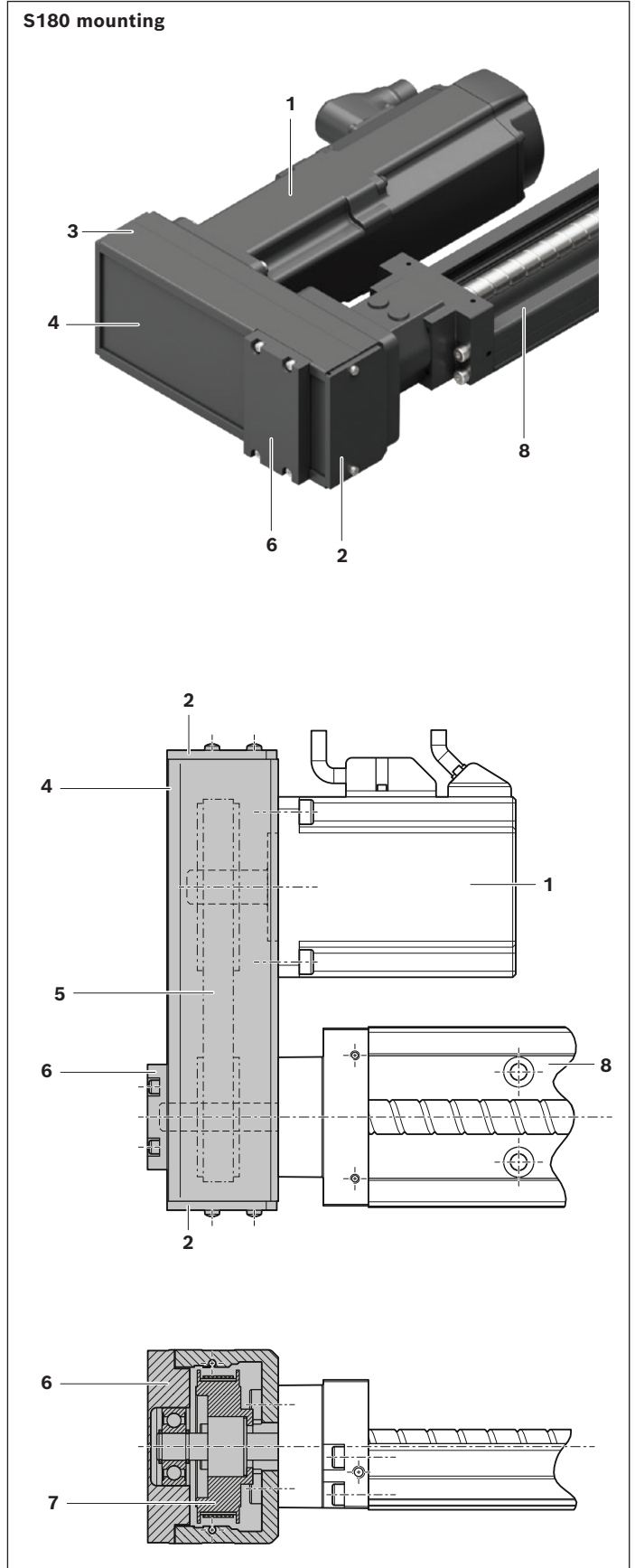

Technical data

General technical data

PSK	Cover	Carriage (TT)		BASA d ₀ x P (mm)	Dynamic load capacities (N)						Dynamic load moments (Nm)			
					C _{bs} Accuracy class ¹⁾		C _{fb}	C _{gw50²⁾}	C _{gw100³⁾}	M _{t50²⁾}	M _{t100³⁾}	M _{L50²⁾}	M _{L100³⁾}	
		N	P	N	P									
050	without / with cover plate	L	1	8x1	1 050	1 180	1 920	5 300	11 500	9 100	170	135	79	63
			2											
	sealing strip	S	1	8x2.5	2 110	2 380	1 920	5 300	11 500	9 100	170	135	79	63
			L											
060	without / with cover plate	S	1	12x2	2 150	2 420	4 200	8 500	11 500	9 100	215	170	79	63
			2											
		L	1	12x5	3 650	4 100	4 200	8 500	14 500	11 500	270	210	140	110
			2											
	sealing strip	S	1	12x10	2 400	2 700	4 200	8 500	14 500	11 500	270	210	140	110
			L											
090	without / with cover plate	S	1	16x5	11 840	13 320	13 400	13 400	27 500	21 800	740	560	280	220
			2											
		L	1	16x10	9 200	10 350	13 400	13 400	35 300	28 000	950	755	490	390
			2											
	sealing strip	S	1	16x16	6 050	6 800	13 400	13 400	27 500	21 800	740	560	280	220
			L											

Note chapter "Calculations".

For names, see chapter "Abbreviations".

¹⁾ Accuracy class: N = normal class, P = precision class. See chapter "Accuracy".

²⁾ Dynamic load capacities and load moments are based on a 50 000 m travel as per DIN ISO 14728-1.

³⁾ Dynamic load capacities and load moments are based on a 100 000 m travel as per DIN ISO 14728-1.

⁴⁾ With a lifting force of F_{z2}, the values for F_{y max} and M_{z max} must be limited to max. 75%.

PSK	Cover	Carriage (TT)		Maximum permissible loads					
				M _{x max} (Nm)	M _{y max} (Nm)	M _{z max} (Nm)	F _{y max} (N)	F _{z1 max} (N)	F _{z2 max⁴⁾} (N)
050	without / with cover plate	L	1	46	22	10	1 400	3 600	3 100
			2	74	2.95 x L _W	1.40 x L _W	2 800	5 900	5 900
	sealing strip	S	1	26	22	10	1 400	3 600	3 600
			L	1	43	177	103	2 800	5 900
060	without / with cover plate	S	1	47	22	10	1 400	3 600	3 100
			2	90	2.95 x L _W	1.40 x L _W	2 800	5 900	5 900
		L	1	70	44	27	2 800	4 600	4 600
			2	112	3.75 x L _W	2.85 x L _W	5 600	7 400	7 400
	sealing strip	S	1	45	44	27	2 800	4 600	4 600
			L	1	73	280	212	5 600	7 400
090	without / with cover plate	S	1	105	46	20	2 000	8 700	4 500
			2	210	4.55 x L _W	2.00 x L _W	4 000	14 100	9 100
		L	1	210	127	56	4 000	11 200	9 100
			2	420	9.10 x L _W	4.00 x L _W	7 900	18 200	18 200
	sealing strip	S	1	78	88	40	4 000	8 700	8 700
			L	1	127	638	359	7 900	14 100

L = Long carriage; S = Standard carriage

PSK	Cover	Carriage (TT)		Moved mass of system			Constant mass calculation						Planar moment of inertia					
				Cover			without		cover plate		sealing strip							
				without	cover plate	sealing strip	k_g fix	k_g var	k_g fix	k_g var	k_g fix	k_g var						
Length	Quantity	m_{ca}	m_{ca}	m_{ca}	(kg)	(kg/mm)	(kg)	(kg/mm)	(kg)	(kg/mm)	I_y	I_z						
				(kg)	(kg)	(kg)	(kg)	(kg/mm)	(kg)	(kg/mm)	(kg)	(kg/mm)	(cm ⁴)	(cm ⁴)				
050	without / with cover plate	L	1	0.18	0.25	-	0.203	0.0041	0.222	0.0043	-	-	1.26	13.76				
			2	0.36	0.51													
	sealing strip	S	1	-	-	0.27					0.252	0.0046						
		L	1	-	-	0.52												
060	without / with cover plate	S	1	0.25	0.35	-	0.366	0.0063	0.393	0.0066	-	-	2.42	28.82				
			2	0.52	0.72													
		L	1	0.34	0.48													
			2	0.69	0.97													
	sealing strip	S	1	-	-	0.5					0.438	0.0071						
		L	1	-	-	0.94												
090	without / with cover plate	S	1	0.79	1.03	-	0.638	0.012	0.719	0.0128	-	-	8.71	115.31				
			2	1.65	2.12													
		L	1	1.07	1.39													
			2	2.2	2.84													
	sealing strip	S	1	-	-	1.17					-	-			-	-	0.809	0.0136
		L	1	-	-	2.25												

L = Long carriage; S = Standard carriage

Modulus of elasticity E of linear motion system

$$E = 210\,000 \text{ N/mm}^2$$

Mass calculation of the linear system (without motor attachment, without motor)

$$m_s = k_{g \text{ fix}} + k_{g \text{ var}} \cdot L + m_{ca}$$

Technical data

PSK	Carriage (TT)		Length (mm)							
	Length	Quantity	without		cover plate		sealing strip		L _{Wmin}	S _{min} ¹⁾
			L _{ca}	L _{ad}	L _{ca}	L _{ad}	L _{ca}	L _{ad}		
050	S	1 TT	–	–	–	–	100	27	–	18
	L	1 TT	39.3	22.5	47.4	14.4	160	27	–	
		2 TT	39.3 + L _W	22.5	47.4 + L _W	14.4	–	–	60	
060	S	1 TT	39.3	20.5	40.0	19.8	130	30	–	25
		2 TT	39.3 + L _W	20.5	40.0 + L _W	19.8	–	–	60	
	L	1 TT	53.7	20.5	55.0	19.2	186	30	–	
		2 TT	53.7 + L _W	20.5	55.0 + L _W	19.2	–	–	75	
090	S	1 TT	57.9	30	60.0	27.9	155	35	–	40
		2 TT	57.9 + L _W	30	60.0 + L _W	27.9	–	–	90	
	L	1 TT	79.6	30	80.0	29.6	230	35	–	
		2 TT	79.6 + L _W	30	80.0 + L _W	29.6	–	–	110	

¹⁾ Minimum required travel range to ensure a reliable lubrication distribution. See chapter "Operating Conditions".
Please consult Bosch Rexroth if it is necessary to go below this value.

PSK -050	L (mm)	S _{max} (mm)		1 TT standard length (sealing strip)	1 TT long (sealing strip)
		Carriage, long 1 TT	Carriage, long 2 TT		
	100	38.2	–	–	–
	150	88.2	28.2	23	–
	200	138.2	78.2	73	–
	250	188.2	128.2	123	63
	300	238.2	178.2	173	113
	350	288.2	228.2	223	163
	400	338.2	278.2	273	213
	500	438.2	378.2	373	313
	600	538.2	478.2	473	413

PSK -060	L (mm)	S _{max} (mm)		Carriage, long		Carriage, standard length (sealing strip) 1 TT	Carriage, long (sealing strip) 1 TT
		Carriage, standard length					
		1 TT	2 TT	1 TT	2 TT		
	150	90.2	30.2	75.8	–	–	–
	200	140.2	80.2	125.8	50.8	40	–
	250	190.2	130.2	175.8	100.8	90	34
	300	240.2	180.2	225.8	150.8	140	84
	400	340.2	280.2	325.8	250.8	240	184
	500	440.2	380.2	425.8	350.8	340	284
	600	540.2	480.2	525.8	450.8	440	384
	700	640.2	580.2	625.8	550.8	540	484
	800	740.2	680.2	725.8	650.8	640	584

PSK -090	L (mm)	S _{max} (mm)		Carriage, long		Carriage, standard length (sealing strip) 1 TT	Carriage, long (sealing strip) 1 TT
		Carriage, standard length					
		1 TT	2 TT	1 TT	2 TT		
	340	252.1	162.1	230.4	120.4	150	75
	440	352.1	262.1	330.4	220.4	250	175
	540	452.1	362.1	430.4	320.4	350	275
	640	552.1	462.1	530.4	420.4	450	375
	740	652.1	562.1	630.4	520.4	550	475
	840	752.1	662.1	730.4	620.4	650	575
	940	852.1	762.1	830.4	720.4	750	675

Length calculation of the linear motion system

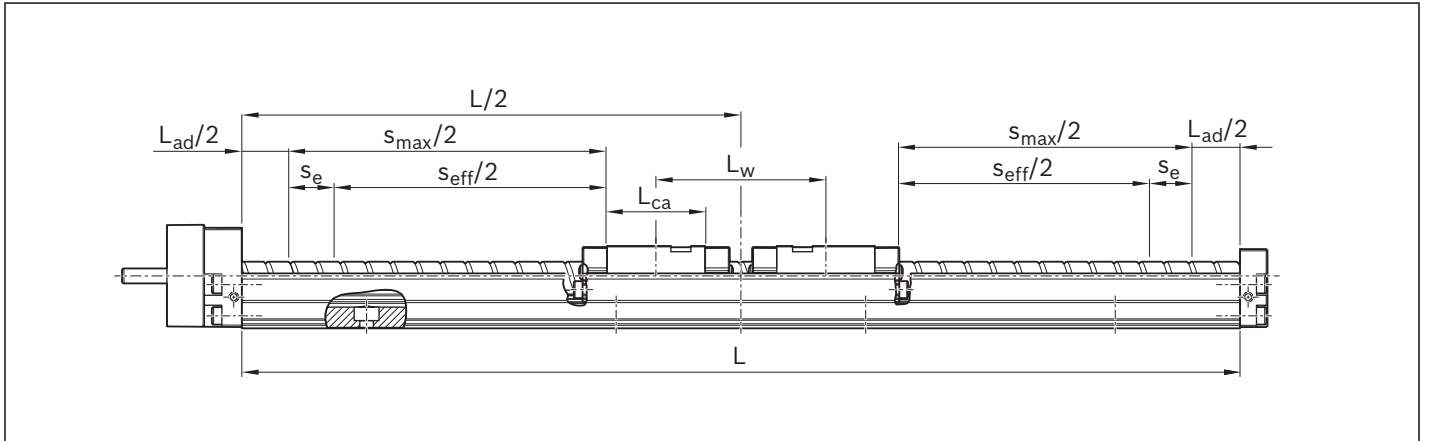

Length¹⁾: $L = s_{eff} + 2 \cdot s_e + L_{ca} + L_{ad}$
 Excess travel: $s_e = 2 \cdot P$
 Max. travel range: $s_{max} = s_{eff} + 2 \cdot s_e$

¹⁾ See chapter "Calculations" and "Configuration and Ordering"

Technical data

Drive data

PSK	Carriage (TT)		BASA	Constant mass moment of inertia					Friction torque	Max. acceleration	Max. drive torque	Max. speed
	Length	Quantity		Cover			$k_{J\text{ var}}$ (kg/mm)	$k_{J\text{ m}}$ (mm ²)				
				without	cover plate	sealing strip						
			$d_0 \times P$ (mm)	$k_{J\text{ fix}}$ (kg/mm ²)	$k_{J\text{ fix}}$ (kg/mm ²)	$k_{J\text{ fix}}$ (kg/mm ²)		M_{RS} (Nm)	a_{max} (m/s ²)	M_P (Nm)	v_{max} (m/s)	
050	S	1 TT	8 x 1	-	-	0.490	0.004	0.025	0.04	48.4	See graphs	See graphs
			8 x 2	-	-	0.513	0.004	0.101	0.04	50.0		
			8 x 2.5	-	-	0.527	0.004	0.158	0.05	50.0		
			8 x 5	-	-	0.671	0.004	0.633	0.06	50.0		
	L	1 TT	8 x 1	0.487	0.489	0.497	0.004	0.025	0.04	48.4		
			8 x 2	0.502	0.509	0.541	0.004	0.101	0.04	50.0		
			8 x 2.5	0.510	0.521	0.571	0.004	0.158	0.06	50.0		
			8 x 5	0.602	0.647	0.843	0.004	0.633	0.07	50.0		
		2 TT	8 x 1	0.492	0.495	-	0.004	0.025	0.04	48.4		
			8 x 2	0.521	0.535	-	0.004	0.101	0.04	50.0		
			8 x 2.5	0.539	0.562	-	0.004	0.158	0.05	50.0		
			8 x 5	0.718	0.808	-	0.004	0.633	0.06	50.0		
060	S	1 TT	12 x 2	0.780	0.790	0.811	0.013	0.101	0.09	48.4		
			12 x 5	0.912	0.976	1.106	0.011	0.633	0.10	50.0		
			12 x 10	1.390	1.646	2.165	0.011	2.533	0.12	50.0		
		2 TT	12 x 2	0.807	0.827	-	0.013	0.101	0.09	48.4		
			12 x 5	1.079	1.206	-	0.011	0.633	0.10	50.0		
			12 x 10	2.056	2.568	-	0.011	2.533	0.11	50.0		
	L	1 TT	12 x 2	0.789	0.803	0.862	0.013	0.101	0.10	48.4		
			12 x 5	0.966	1.055	1.425	0.011	0.633	0.11	50.0		
			12 x 10	1.605	1.963	3.442	0.011	2.533	0.13	50.0		
		2 TT	12 x 2	0.824	0.851	-	0.013	0.101	0.09	48.4		
			12 x 5	1.188	1.357	-	0.011	0.633	0.10	50.0		
			12 x 10	2.494	3.168	-	0.011	2.533	0.11	50.0		
090	S	1 TT	16 x 5	4.417	4.566	4.702	0.031	0.633	0.24	50.0		
			16 x 10	5.941	6.539	7.084	0.031	2.533	0.25	50.0		
			16 x 16	9.111	10.641	12.035	0.034	6.485	0.26	50.0		
		2 TT	16 x 5	4.943	5.242	-	0.031	0.633	0.24	50.0		
			16 x 10	8.049	9.245	-	0.031	2.533	0.25	50.0		
			16 x 16	14.506	17.566	-	0.034	6.485	0.27	50.0		
	L	1 TT	16 x 5	4.594	4.796	5.411	0.031	0.633	0.25	50.0		
			16 x 10	6.651	7.459	9.921	0.031	2.533	0.27	50.0		
			16 x 16	10.926	12.995	19.298	0.034	6.485	0.30	50.0		
		2 TT	16 x 5	5.303	5.707	-	0.031	0.633	0.24	50.0		
			16 x 10	9.488	11.104	-	0.031	2.533	0.25	50.0		
			16 x 16	18.189	22.326	-	0.034	6.485	0.27	50.0		

Note chapter "Calculations".

For names, see chapter "Abbreviations".

Drive data for motor attachment via belt side drive

PSK	Motor	BASA $d_0 \times P$ (mm)	Permissible torque		Reduced mass moment of inertia		Friction torque M_{Rsd} (Nm)	Mass		Belt type	
			$M_{sd}^{1)}$ (Nm)	$M_{sd}^{1)}$ (Nm)	J_{sd} (10^{-6} kg/ m^2)	J_{sd} (10^{-6} kg/ m^2)		m_{sd} (kg)	m_{sd} (kg)	B_t 	B_t
050	MSM019B	8 x 1	0.21	0.14	10.70	4.10	0.06	0.27	0.25	6AT3	6AT3
		8 x 2	0.50	0.33							
		8 x 2.5	0.61	0.41							
		8 x 5	0.60	0.40							
060	MSM019B	12 x 2	0.86	0.57	10.70	4.10	0.06	0.28	0.26	6AT3	6AT3
		12 x 5	1.31	0.87							
		12 x 10	1.31	0.87							
	MSM031B	12 x 2	0.86	0.57	34.77	13.05	0.15	0.63	0.60	10AT3	10AT3
		12 x 5	2.47	1.65							
		12 x 10	2.70	1.80							
MS2N03-B	12 x 2	0.86	0.57	34.27	12.45	0.15	0.63	0.61	10AT3	10AT3	
	12 x 5	2.47	1.65								
	12 x 10	2.70	1.80								
090	MSM031C	16 x 5	2.87	1.91	41.50	13.30	0.15	0.67	0.64	10AT3	10AT3
		16 x 10	2.87	1.91							
		16 x 16	2.87	1.91							
	MSM041B	16 x 5	4.32	2.88	233.90	79.10	0.40	1.45	1.28	16AT5	16AT5
		16 x 10	5.86	3.91							
		16 x 16	6.43	4.29							
	MS2N03-B (i=1.5) MS2N03-D (i=1)	16 x 5	2.87	1.91	37.30	13.40	0.15	0.65	0.65	10AT3	10AT3
		16 x 10	2.87	1.91							
		16 x 16	2.87	1.91							
	MS2N04	16 x 5	4.32	2.88	234.40	83.60	0.40	1.42	1.32	16AT5	16AT5
16 x 10		5.86	3.91								
16 x 16		6.43	4.29								

Drive data for motor attachment via flange and coupling

PSK	Motor	Coupling	$M_{cN}^{1)}$	J_c	m_{fc}
			(Nm)	(10^{-6} kg/ m^2)	(kg)
050	MSM019B		1.90	2.10	0.089
	MSM031B		3.70	7.00	0.300
	MS2N03-B		3.70	7.00	0.300
	NEMA-17C		-	-	0.038
060	MSM019B		1.90	2.10	0.126
	MSM031B		3.70	7.00	0.300
	MS2N03-B		1.90	2.10	0.164
	NEMA 23-D		-	-	0.123
090	MSM031C		13.00	12.00	0.370
	MSM041B		9.00	61.00	0.800
	MS2N03-B MS2N03-D		13.00	12.00	0.377
	MS2N04		19.00	57.00	0.750
	NEMA 23-D		-	-	0.272

1) Values for M_{sd} / M_{cN} do not factor in motor torque.

Speed diagrams

Drive torque diagrams

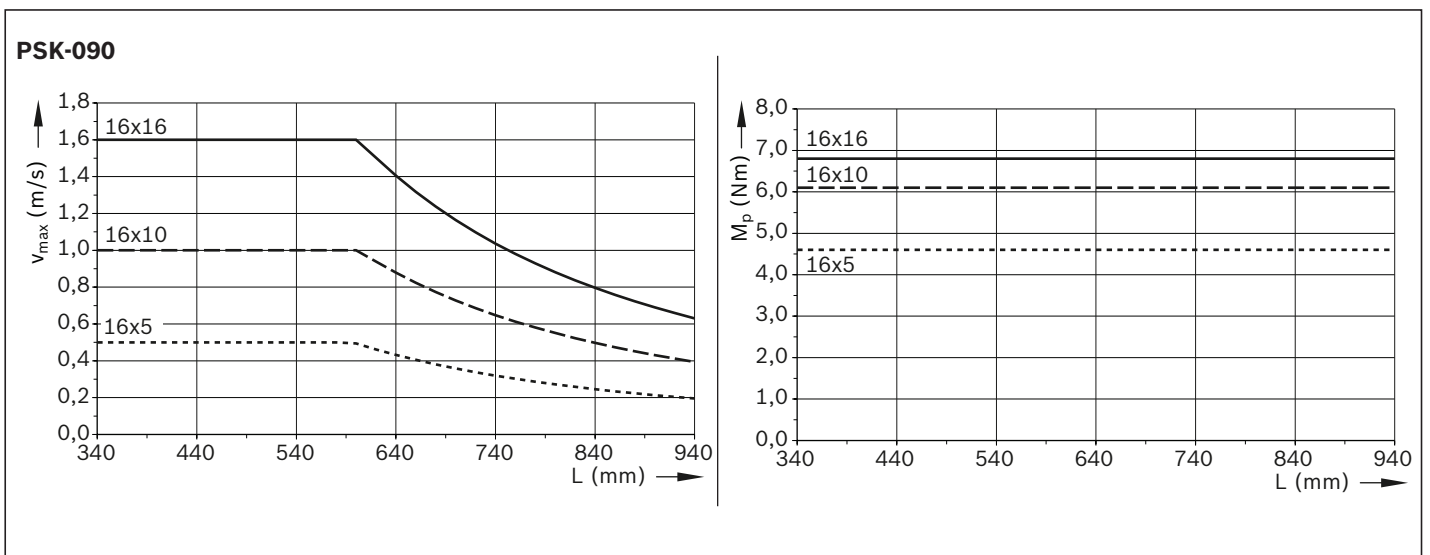
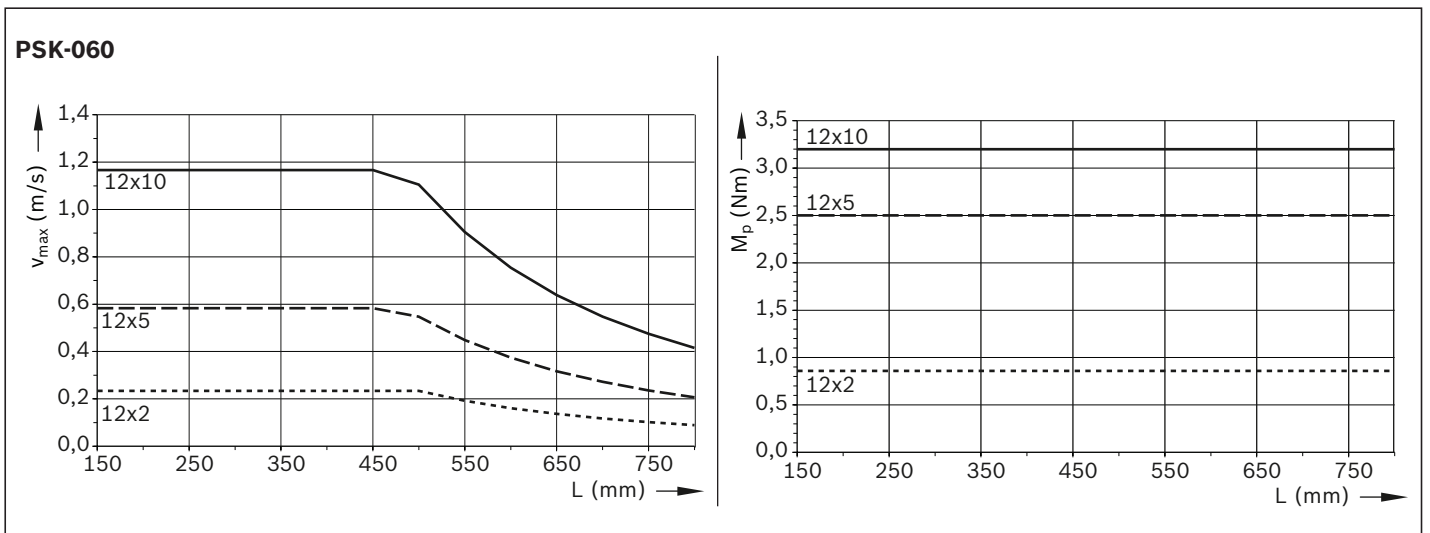
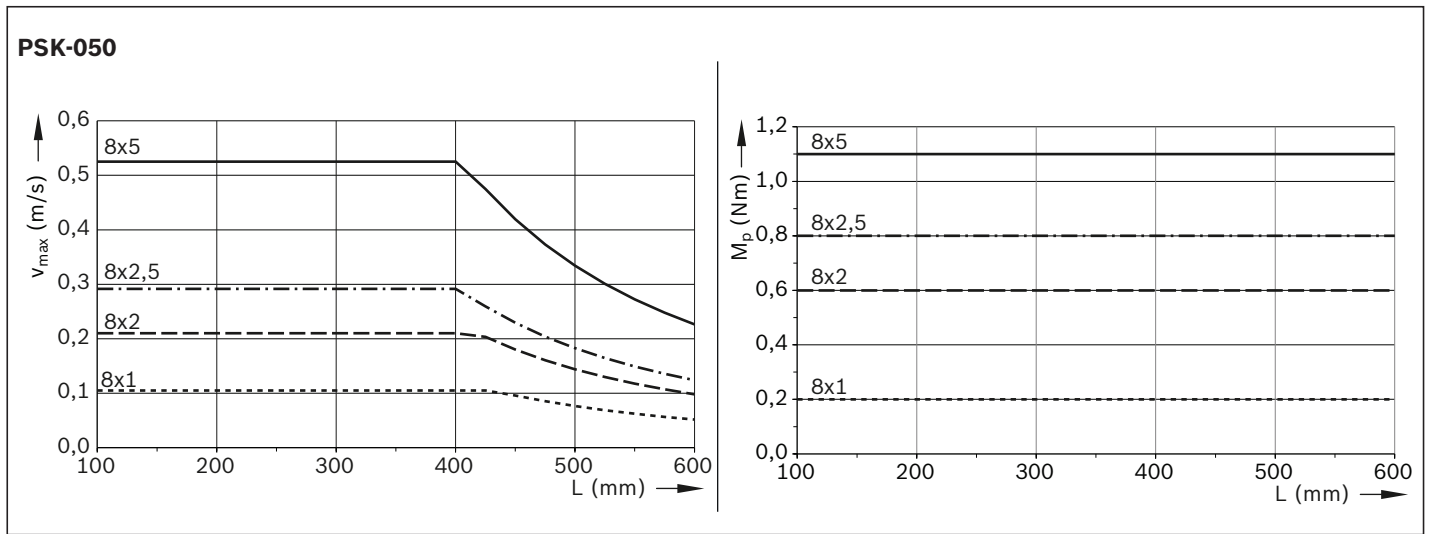

Speed and drive torque values

PSK-050												
Length (mm)	100, 150, 200, 250, 300, 350, 400				500				600			
BASA	8x1	8x2	8x2.5	8x5	8x1	8x2	8x2.5	8x5	8x1	8x2	8x2.5	8x5
v_{max} (m/s)	0.11	0.21	0.29	0.53	0.08	0.14	0.18	0.33	0.05	0.10	0.12	0.23
M_p (Nm)	0.20	0.60	0.80	1.10	0.20	0.60	0.80	1.10	0.20	0.60	0.80	1.10

PSK-060															
Length (mm)	150, 200, 250, 300, 400			500			600			700			800		
BASA	12x2	12x5	12x10	12x2	12x5	12x10	12x2	12x5	12x10	12x2	12x5	12x10	12x2	12x5	12x10
v_{max} (m/s)	0.23	0.58	1.17	0.23	0.55	1.11	0.16	0.37	0.75	0.12	0.27	0.55	0.09	0.21	0.42
M_p (Nm)	0.86	2.50	3.20	0.86	2.50	3.20	0.86	2.50	3.20	0.86	2.50	3.20	0.86	2.50	3.20

PSK-090															
Length (mm)	340, 440, 540			640			740			840			940		
BASA	16x5	16x10	16x16	16x5	16x10	16x16	16x5	16x10	16x16	16x5	16x10	16x16	16x5	16x10	16x16
v_{max} (m/s)	0.50	1.00	1.60	0.43	0.88	1.41	0.32	0.65	1.04	0.25	0.50	0.80	0.19	0.39	0.63
M_p (Nm)	4.60	6.10	6.80	4.60	6.10	6.80	4.60	6.10	6.80	4.60	6.10	6.80	4.60	6.10	6.80

Accuracy diagrams

General note

All accuracy figures apply to the module when screwed down and assume an ideally flat clamping surface. The values given do not take into consideration any deviations in the clamping surface.

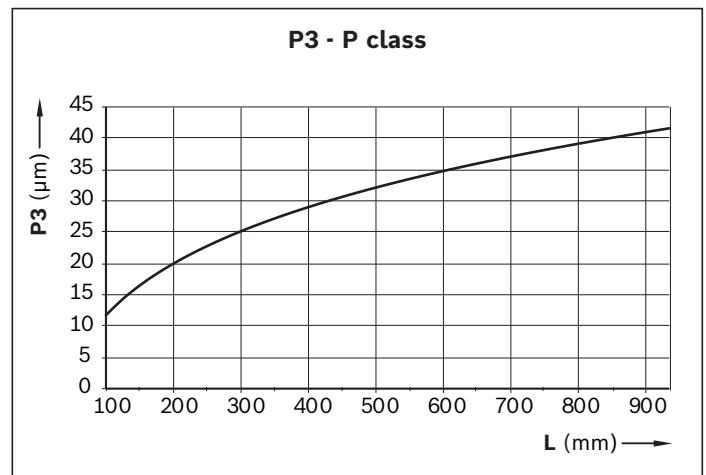
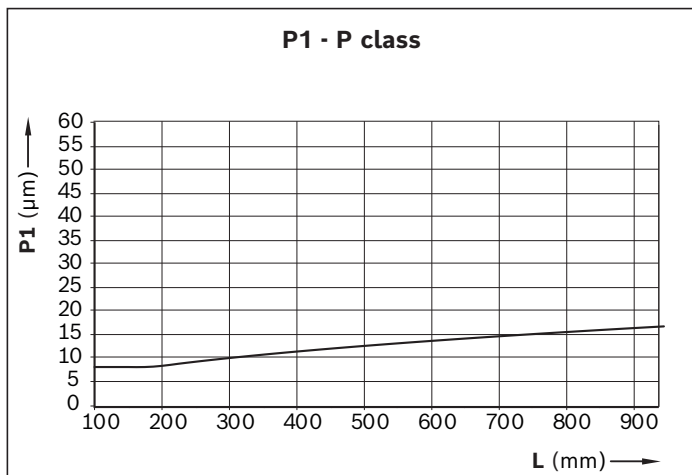
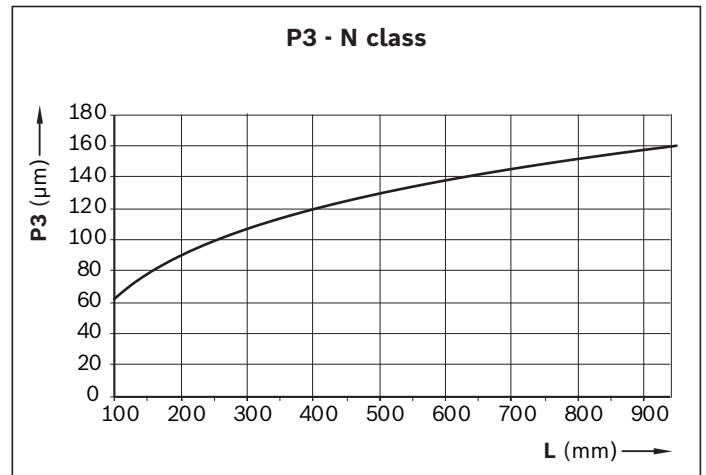
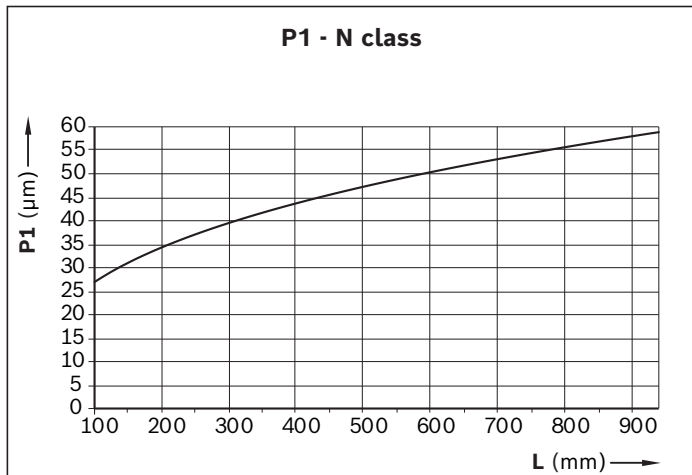
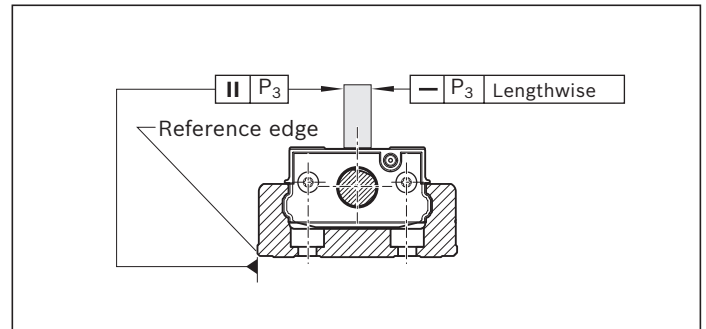
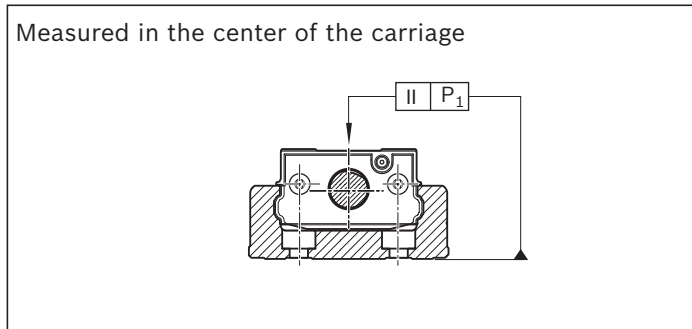

Axial backlash

PSK	Axial backlash	
	Accuracy class	
	N (mm)	P (mm)
050	Max. 0.045 mm clearance	Max. 0.003 mm clearance
060		
090		

Calculation principles

Calculation principles

- Maximum permissible loads 25
- Linear guide service life 25
- Service life of ball screw assembly or the fixed bearing 26

Drive sizing

- Basic principles 27
- Drive sizing with motor shaft as reference point 28
- General motor preselection 30

Calculation example

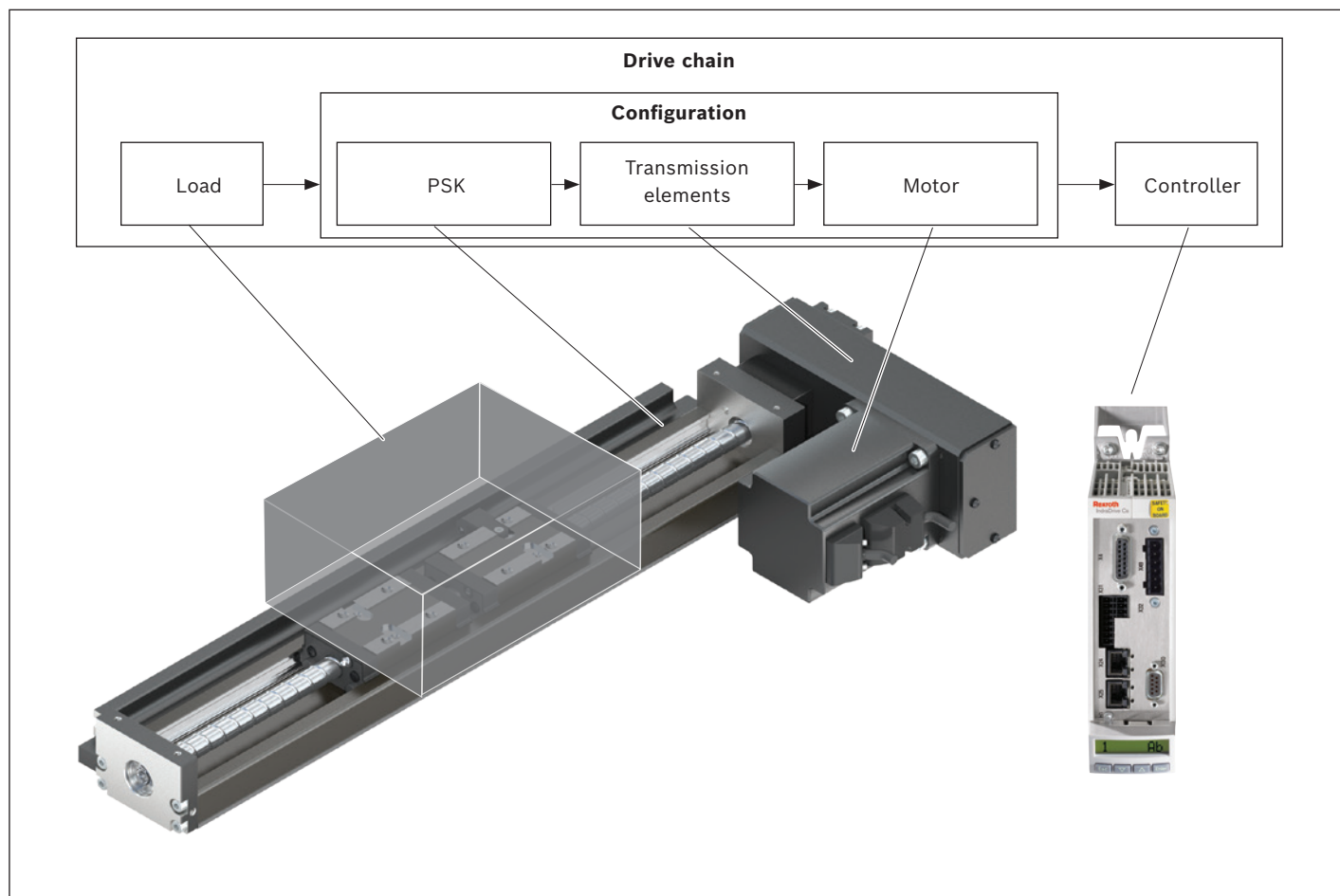

The correct dimensioning and assessment of an application requires structured consideration of the entire drive chain. The configuration, which comprises the precision module PSK, the transmission element (coupling or belt side drive) and the motor, forms the base of the drive chain and can be ordered from the catalog in this combination.

Maximum permissible loads

When selecting a linear motion system, the maximum permissible loads and forces must be taken into account and can be found in the chapter "Technical Data". The values in this chapter are system-based, i.e. the limits are based not only on the load capacity of the bearings, but also on design/material limits.

Conditions for combined loads

$$\frac{|F_y|}{F_{y \max}} + \frac{|F_z|}{F_{z \max}} + \frac{|M_x|}{M_{x \max}} + \frac{|M_y|}{M_{y \max}} + \frac{|M_z|}{M_{z \max}} \leq 1$$

Linear guide service life

The service life of the rolling bearing points contained in a linear motion system can be calculated using the formulas given below. The roller bearings that determine the life of a linear motion system with ball screw assembly are the linear guide, the ball screw assembly (nut) and the fixed bearing.

△ The service life of the linear motion system is the separately calculated service life that is the shortest (for linear guide, ball screw assembly or fixed bearing).

The linear guide in the linear motion system must withstand the load as well as any process forces that occur.

Combined equivalent load on bearing of the guideway

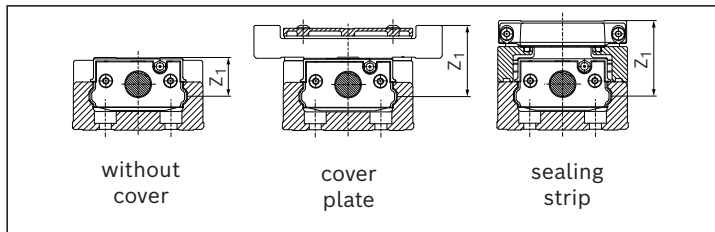

	z ₁ (mm)		
	without cover	cover plate	sealing strip
PSK-050	13.0	27.0	27.0
PSK-060	17.5	32.5	34.5
PSK-090	24.5	46.5	46.5

$$F_{\text{comb}} = |F_y| + |F_z| + C \cdot \frac{|M_x|}{M_t} + C \cdot \frac{|M_y|}{M_L} + C \cdot \frac{|M_z|}{M_L}$$

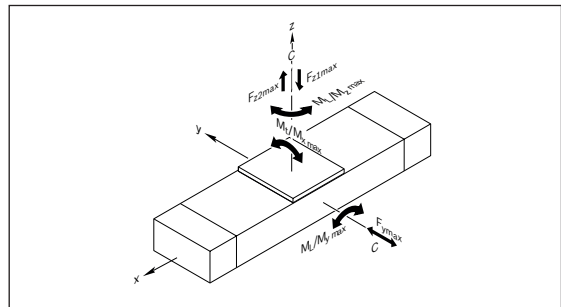

$$L = \left(\frac{C_{100}}{f_w \cdot F_{\text{comb}}} \right)^3 \cdot 10^5 \text{ m}$$

Nominal service life in meters

Impact loads and vibrations cause additional loads on the contact point between ball and running track.

Determining the exact conditions of use is difficult. However, the additional loads increase as travel speed increases.

The load factor f_w (see table) factors in the effects of impacts and vibrations on service life.

Conditions of use	Travel speed	Load factor f_w
No impact loads and vibrations	$v < 0.25 \text{ m/s}$	1.0 ... 1.2
Low impact loads and vibrations	$0.25 \text{ m/s} \leq v < 1 \text{ m/s}$	1.2 ... 1.5
Moderate impact loads and vibrations	$1 \text{ m/s} \leq v < 2 \text{ m/s}$	1.5 ... 2.0
High impact loads and vibrations	$v \geq 2 \text{ m/s}$	2.0 ... 3.5

Nominal service life in hours

$$L_h = \frac{L}{3600 \cdot v}$$

Calculation principles

Service life of ball screw assembly or the fixed bearing

Under variable operating conditions (variable rotary speed and load), the means F_m and n_m have to be used when calculating the service life.

If rotary speed varies, average rotary speed n_m is calculated as follows:

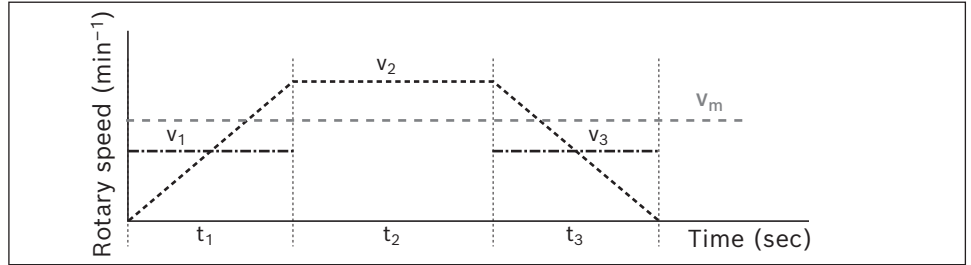

$$n_m = \frac{|n_1| \cdot t_1 + |n_2| \cdot t_2 + \dots + |n_n| \cdot t_n}{t_{ges}}$$

$$t_{ges} = t_1 + t_2 + \dots + t_n$$

Rotary speed in acceleration and braking phases $n_{1 \dots n}$:

$$n_{1 \dots n} = \frac{n_{A1 \dots n} + n_{E1 \dots n}}{2}$$

When both the load and the rotary speed vary, the average load F_m is calculated as follows:

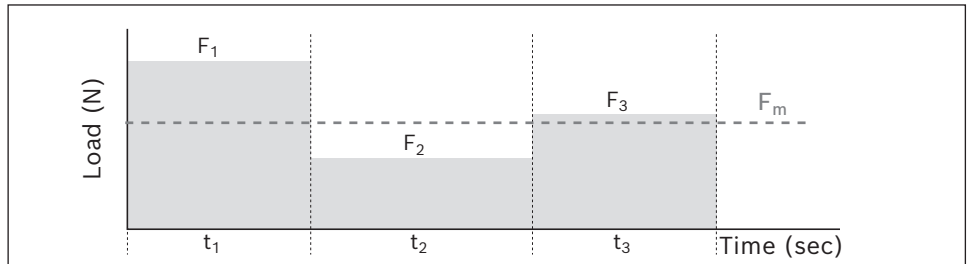

$$F_m = \sqrt[3]{|F_1|^3 \cdot \frac{|n_1|}{n_m} \cdot \frac{t_1}{t_{ges}} + |F_2|^3 \cdot \frac{|n_2|}{n_m} \cdot \frac{t_2}{t_{ges}} + \dots + |F_n|^3 \cdot \frac{|n_n|}{n_m} \cdot \frac{t_n}{t_{ges}}}$$

Nominal service life

Nominal service life in revolutions:

$$L = \left(\frac{C}{F_m} \right)^3 \cdot 10^6$$

Nominal service life in hours:

$$L_h = \frac{L}{n_m \cdot 60}$$

Drive sizing

Basic principles

For drive sizing, the drive chain can be divided into mechanical system and drive system.

The mechanical system includes the physical components linear motion system and transmission elements (belt side drive, coupling) as well as the load to be carried.

The electric drive is a motor-controller combination with corresponding performance data.

The sizing and/or dimensioning of the electric drive is done taking the motor shaft as a reference point.

For drive sizing, limits must be taken into account as well as base values. The limits must not be exceeded in order to avoid damaging the mechanical components.

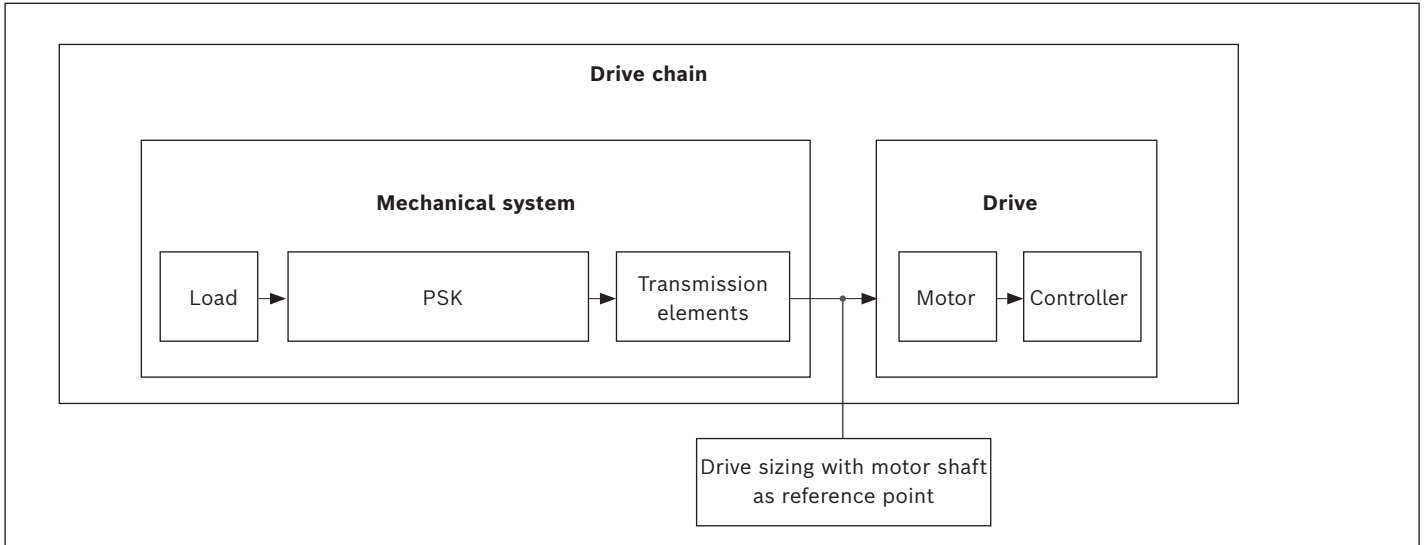

Technical data and formula symbols for the mechanical system

For every component (linear motion system, coupling, belt side drive), the corresponding maximum permissible limits for drive torque and speed, and the base values for friction torque and mass moment of inertia have to be used.

The following technical data with the associated formula symbols are used when considering the basic mechanical system requirements in the design calculations for the drive sizing. The data listed in the table below can be found in the chapter "Technical Data" or is determined using formulas based on the descriptions on the following pages.

		Load	Mechanical system		
			Linear motion system	Coupling	Belt side drive
Weight moment	(Nm)	$M_g^{6)}$	—	—	—
Friction torque	(Nm)	— ⁵⁾	$M_{Rs}^{3)}$	—	$M_{Rsd}^{3)}$
Mass moment of inertia	(kg/m ²)	$J_t^{1)}$	$J_s^{2)}$	$J_c^{3)}$	$J_{sd}^{3)}$
Max. permissible speed	(m/s)	—	$v_{max}^{4)}$	—	—
max. permissible drive torque	(Nm)	—	$M_p^{4)}$	$M_{cN}^{3)}$	$M_{sd}^{3)}$

- 1) Determine the value using the appropriate formula
- 2) Length-dependent value, determined using the appropriate formula
- 3) Use the value from the table
- 4) Length-dependent value, to be read off the graph
- 5) Any additional process forces are to be taken into consideration as load moments
- 6) For vertical installation position: Determine the value using the appropriate formula

Drive sizing

Drive sizing with motor shaft as reference point

When sizing the drive, all relevant design calculation values for the mechanical components in the drive chain have to be determined and be expressed/reduced to the motor shaft. For a combination of mechanical components within the drive chain, this will result in one value for each of the following:

- Friction torque M_R
- Mass moment of inertia J_{ex}
- Max. permissible speed v_{mech} (max. permissible rotary speed n_{mech})
- Max. permissible drive torque M_{mech}

Determination of the values for each mechanical component in the drive chain based on the motor shaft as a reference point

Friction torque M_R

For motor attachment via flange and coupling

$$M_R = M_{Rs}$$

For motor attachment via belt side drive

$$M_R = M_{Rsd} + \frac{M_{Rs}}{i}$$

Mass moment of inertia J_{ex}

For motor attachment via flange and coupling

$$J_{ex} = J_s + J_t + J_c$$

For motor attachment via belt side drive

$$J_{ex} = J_{sd} + \frac{(J_s + J_t)}{i^2}$$

Determination of mass moment of inertia of linear motion system components

$$J_s = (k_{J \text{ fix}} + k_{J \text{ var}} \cdot L) \cdot 10^{-6}$$

Determination of translative mass moment of inertia of external load

$$J_t = m_{ex} \cdot k_{J m} \cdot 10^{-6}$$

Maximum permissible speed v_{mech}

The lowest of all the values for the maximum permissible speed of all mechanical components contained in the drive chain determines the maximum permissible speed of the mechanical system which has to be taken into consideration as the upper limit for the drive when sizing the motor. Depending on the system, the maximum permissible speed/rotary speed of the linear motion system with ball screw assembly is always below the limits for the coupling or belt side drive components, meaning it determines the maximum permissible speed of the mechanical system.

Maximum permissible speed

$$v_{\text{mech}} = v_{\text{max}}$$

Maximum permissible rotary speed

For motor attachment via flange and coupling

$$n_{\text{mech}} = \frac{v_{\text{mech}} \cdot 1000 \cdot 60}{P}$$

For motor attachment via belt side drive

$$n_{\text{mech}} = \frac{v_{\text{mech}} \cdot i \cdot 1000 \cdot 60}{P}$$

Maximum permissible drive torque M_{mech}

The lowest (minimum) of all the values for permissible drive torque of all mechanical components contained in the drive chain determines the maximum permissible drive torque of the mechanical system which has to be taken into consideration as the upper limit for the drive when sizing the motor.

For motor attachment via flange and coupling

$$M_{\text{mech}} = \text{minimum} (M_{\text{cN}}; M_{\text{p}})$$

For motor attachment via belt side drive

$$M_{\text{mech}} = \text{minimum} (M_{\text{sd}}; \frac{M_{\text{p}}}{i})$$

△ When considering the complete drive chain (mechanical system + motor/controller), the maximum torque of the motor can lie below the maximum value for the mechanical system (M_{mech}) and thus limit the maximum permissible drive torque of the overall drive chain.

If the maximum torque of the motor lies above the upper limit for the mechanical system (M_{mech}), the maximum motor torque must be limited to the permissible value for the mechanical system.

Drive sizing

General motor preselection

The motor can be generally preselected using the following conditions.

Condition 1:

The rotary speed of the motor must be greater than or equal to the rotary speed required for the mechanical system (but not exceeding the maximum permissible limit value).

$$n_{\max} \geq n_{\text{mech}}$$

Condition 2:

Consideration of the ratio of mass moments of inertia of the mechanical system and the motor. The ratio of the mass moments of inertia serves as an indicator for the control performance of a motor-controller combination.

The mass moment of inertia of the motor is directly related to the motor size.

Ratio of mass moments of inertia

$$V = \frac{J_{\text{ex}}}{J_m + J_{\text{br}}}$$

For preselection, experience has shown that the following ratios will result in high control performance.

These are not rigid limits, but values exceeding them will require closer consideration of the specific application.

Application area	V
Handling	≤ 6.0
Machining	≤ 1.5

Condition 3:

Estimation of the ratio of the static load moment to the continuous torque of the motor. The torque ratio must be less than or equal to an empirical value of 0.6. This condition roughly factors in the missing dynamic characteristics of an exact motion profile with the required motor torques.

Torque ratio

$$\frac{M_{\text{stat}}}{M_0} \leq 0.6$$

Static load moment

$$M_{\text{stat}} = M_R + M_g$$

Weight moment

For vertical installation position only!

For motor attachment via flange
and coupling: $i = 1$

$$M_g = \frac{P \cdot (m_{\text{ex}} + m_{\text{ca}}) \cdot g}{2000 \cdot \pi \cdot i}$$

In the chapter ➡ "Configuration and Ordering", standardized configurations that include motor attachment and motor can be created for the various linear motion system sizes by selecting options. By checking the above conditions, it is possible to see whether a standard motor selected in a particular configuration will generally be of a suitable size for the specific application.

Precise drive sizing

Preselecting the motor according to this rough guide is no substitute for the required precise design calculations for the drive, taking all moments/torques and rotary speed levels into account. For precise calculation of the electric drive, including consideration of the specific motion profile, please refer to the performance data in the catalog "Rexroth drive technology".

When sizing the drive, the maximum permissible values for linear speed, drive torque and acceleration must not be exceeded, in order to avoid damaging the mechanical system.

Calculation example

Given data

The mass 20 kg is to be moved by 340 mm at a maximum speed of 0.6 m/s.

Module selected based on the technical data and the installation dimensions:

- PSK 090 without cover and with a standard length carriage
- Motor attachment via flange and coupling
- Motor type: MS2N03-D0BYN

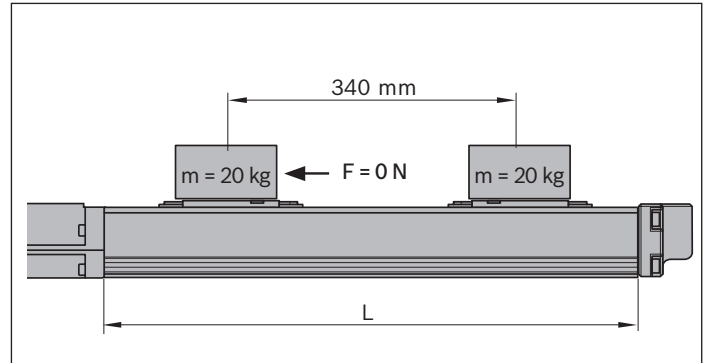

Estimation of length L

(For an initial estimate, the greatest possible lead, thus the length, is calculated, since the permissible speed can decrease as length increases.)

	$L = s_{\text{eff}} + 2 \cdot s_e + L_{\text{ca}} + L_{\text{ad}}$
Excess travel:	$s_e = 2 \cdot P = 2 \cdot 16 = 32 \text{ mm}$
Max. travel range:	$s_{\text{max}} = s_{\text{eff}} + 2 \cdot s_e$
	$= 340 + 2 \cdot 32 = 404 \text{ mm}$
Length:	$L = 404 + 57.9 + 30 = 491.9 \text{ mm}$
Selected:	Standard length $L = 540 \text{ mm}$

Selection of the ball screw assembly

(Ideally, select the lowest lead, since it is favorable to braking distance decay, length.)

Permissible ball screw assembly according to the graph at $v = 0.6 \text{ m/s}$ and $L = 540 \text{ mm}$: KGT 16 x 10 and KGT 16 x 16;
 Selected ball screw assembly (lower lead): KGT 16 x 10;
 v_{max} for KGT 16 x 10 from graph: = 1.0 m/s

Calculation of length L

(For selected ball screw assembly)

Excess travel:	$s_e = 2 \cdot P = 2 \cdot 10 = 20 \text{ mm}$
Max. travel range:	$s_{\text{max}} = s_{\text{eff}} + 2 \cdot s_e$
	$= 340 + 2 \cdot 20 = 380 \text{ mm}$
Length:	$L = 380 + 57.9 + 30 = 467.9 \text{ mm}$
Selected:	Standard length $L = 540 \text{ mm}$

Calculation example (continued)

Friction torque M_R

$$M_R = M_{RS} = 0.19 \text{ Nm (see "Technical Data")}$$

Mass moment of inertia J_{ex}

Mass moment of inertia:	$J_{ex} = J_s + J_t + J_c$
PSK:	$J_s = (k_{J \text{ fix}} + k_{J \text{ var}} \cdot L)$ $= (5.941 + 0.031 \cdot 540 \text{ mm}) \cdot 10^{-6} = 22.681 \cdot 10^{-6} \text{ kg/m}^2$
External load:	$J_t = m_{ex} \cdot k_{J \text{ m}} \cdot 10^{-6}$ $= 20 \text{ kg} \cdot 2.533 \cdot 10^{-6} \text{ kg/m}^2 = 50.66 \cdot 10^{-6} \text{ kg/m}^2$
	$J_c = 12 \cdot 10^{-6} \text{ kg/m}^2$
Coupling:	$J_{ex} = (22.681 + 50.66 + 12) \cdot 10^{-6} \text{ kg/m}^2 = 85.341 \cdot 10^{-6} \text{ kg/m}^2$

Maximum permissible rotary speed n_{mech}

Limit for mechanical system

$$n_{mech} = \frac{(v_{mech} \cdot 1000 \cdot 60)}{p}$$

Max. permissible speed: $v_{mech} = v_{max} = 1.0 \text{ m/s}$

Max. permissible rotary speed: $n_{mech} = \frac{(1.0 \cdot 1000 \cdot 60)}{10} = 6000 \text{ min}^{-1}$

Maximum rotary speed of the application n_{mech}

Application tolerance

Travel speed:	$v_{mech} = 0.6 \text{ m/s}$
Rotary speed:	$n_{mech} = \frac{0.6 \cdot 1000 \cdot 60}{10} = 3600 \text{ min}^{-1}$

Maximum permissible drive torque M_{mech}

Limit for mechanical system

	$M_{mech} = \text{Minimum } (M_{cN}; M_p)$
Coupling:	$M_{cN} = 13 \text{ Nm (for MS2N03-D0BYN)}$
PSK:	$M_p = 6.1 \text{ Nm}$
Drive torque:	$M_{mech} = \text{Minimum } (13; 6.1) = 6.1 \text{ Nm}$

Motor preselection check

Selected motor:
MS2N03-D0BYN with brake

Condition 1:

Rotary speed: $n_{\max} \geq n_{\text{mech}}$; $9000 \geq 3600$ Condition met – motor selection OK

Condition 2:

Mass moment of inertia ratio: $V = \frac{J_{\text{ex}}}{J_{\text{m}} + J_{\text{br}}} =$

Motor inertia: $J_{\text{m}} = 37 \cdot 10^{-6} \text{ kg/m}^2$

Brake moment of inertia: $J_{\text{br}} = 7 \cdot 10^{-6} \text{ kg/m}^2$

Moment of inertia ratio: $V = \frac{85.341 \cdot 10^{-6}}{(37 \cdot 10^{-6} + 7 \cdot 10^{-6})} = 1.94$

Handling condition: $V \leq 6$

$1.94 \leq 6$ Condition met – motor selection OK

Condition 3:

Torque ratio: $\frac{M_{\text{stat}}}{M_0} \leq 0.6$

Static load moment: $M_{\text{stat}} = M_{\text{R}} + M_{\text{g}}$ (installed horizontally $M_{\text{g}} = 0$)
 $= 0.19 \text{ Nm}$

Continuous motor torque: $M_0 = 1.15 \text{ Nm}$

Torque ratio: $\frac{0.19}{1.15} = 0.17$

$0.17 \leq 0.6$ Condition met – motor selection OK

All three conditions met \Rightarrow selected motor is suitable for the application.

Result

PSK-090

$L = 540 \text{ mm}$; $s_{\max} = 447 \text{ mm}$; $L_{\text{ca}} = 57.9 \text{ mm}$; $d_0 = 16 \text{ mm}$; $P = 10 \text{ mm}$;

Without cover; motor attachment via flange and coupling;

Motor preselection: MS2N03-D0BYN with brake.

For the exact sizing of the electric drive, the motor-controller combination always has to be factored in, since the performance data (e.g. maximum useful speed and maximum torque) depends on the controller used. When doing this, the following data must be considered:

Friction torque: $M_{\text{R}} = 0.19 \text{ Nm}$

Mass moment of inertia: $J_{\text{ex}} = 85.341 \cdot 10^{-6} \text{ kg/m}^2$

Travel speed: $v_{\text{mech}} = 0.6 \text{ m/s}$ ($n_{\text{mech}} = 3600 \text{ min}^{-1}$)

Drive torque limit: $M_{\text{mech}} = 6.1 \text{ Nm}$







\Rightarrow The motor torque must be limited to 6.1 Nm on the drive side!

Acceleration limit: $a_{\max} = 50 \text{ m/s}^2$

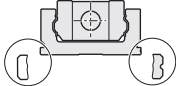
Limit for speed: $v_{\max} = 1 \text{ m/s}$ ($n_{\text{mech}} = 6000 \text{ min}^{-1}$)

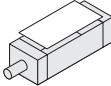
Besides the preferred type MS2N03-D0BYN, other motors with identical connection dimensions can be adapted while taking care not to exceed the calculated limit values.

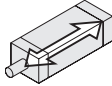
PSK-050-NN-2 Configuration and ordering

Accuracy class	Length ¹⁾	Reference edge		Lubrication ²⁾	Cover			Drive	Carriage			
		Left	Right		without	with cover plate	with sealing strip		BASA d ₀ x P	Standard	Long	Quantity
N = normal class P = precision class	L (mm)											
N	100			LSS				8 x 1				
	150				0	1	-	8 x 2	-	L	1	2
	200							8 x 2.5				
	250			LPG				8 x 5				
	300	L	R									
	P	350			LCF				8 x 1			
400								8 x 2				
500				LSC	-	-	2	8 x 2.5	S	L	1	-
600								8 x 5				

¹⁾ For length calculation, see chapter "Technical Data".

²⁾ See chapter "Lubrication and Maintenance". Lubrication version "LSC".

³⁾ Attachment kit also available without motor. When ordering, enter motor type "000".

For attachment kits according to customer specifications, see chapter "Attachment Kits for Motors according to Customer Specifications".





With servo motor attached, product only available as assembled in the chapter "Form of Delivery" (note position of motor connector).

⁴⁾ Use motors complying with the appropriate NEMA specification.

Due to the varying journal dimensions for NEMA-specification motors, the attachment kit does not include a coupling.

⁵⁾ Permissible motor connector position (for "with motor" option only). For mechanical interface without motor: option code "000".

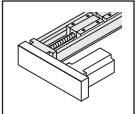
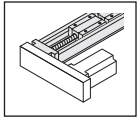
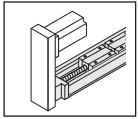
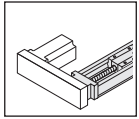
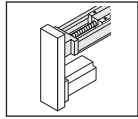
⁶⁾ For more information, see chapter "Switching System".

Version	Mounting interface ³⁾		Motor						Switching system ⁶⁾		Documentation	
	Gear ratio	Mechanical interface	Motor code	Connection		Holding brake		Motor connector position ⁵⁾				
				1 cable	2 cables	with	without					
		F000										
F000 (without flange)	-	-	-	-	-	-	-					
		F001										
F001 (with flange)	i = 1.0	MSM019B	MSM019B-0300	-	2	Y	N		000	without sensor	without cable duct, without switching cam	001 standard report 002 friction torque 003 lead deviation 004 travel accuracy 005 positional uncertainty
		MSM031B	MSM031B-0300	-	2				090			
		MS2N03-B	MS2N03-B0BYN	1	-				180			
		NEMA 17-C ⁴⁾	-	-	-				270			
												
S000 S090 S180 S270 (with belt side drive)	i = 1.0	MSM019B	MSM019B-0300	-	2	Y	N		000	120 Sensor (PNP NC) 121 Sensor (NPN NC) 122 Sensor (PNP NO) 123 Sensor (NPN NO)	with cable duct, with switching cam for 001 (without/with cover plate) 002 (with sealing strip)	
									i = 1.5			

Flange	Motor connector position			
	0°	90°	180°	270°
F001	000	090 ★	180	270

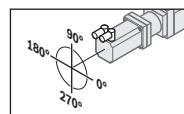

Example:
Flange F001
Motor connector position 90°

Belt side drive	Motor connector position			
	0°	90°	180°	270°
S000	-	090	180 ★	270
S090	000	090 ★	180	-
S180	000 ★	090	-	270
S270	000	-	180	270 ★

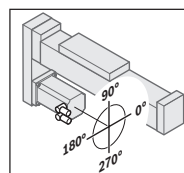





Example:
Timing belt side drive S270
Motor connector position 180°

★ Standard delivery (connector position)

PSK-060-NN-2 Configuration and ordering

Accuracy class	Length ¹⁾	Reference edge		Lubrication ²⁾	Cover			Drive	Carriage				
		Left	Right		without	with cover plate	with sealing strip		BASA d ₀ x P	Standard	Long	Quantity	
N = normal class P = precision class	L (mm)												
N	150			LSS				12 x 2					
	200				0	1	-	12 x 5	S	L	1	2	
	250												
	300			LPG				12 x 10					
P	400	L	R										
	500			LCF									
	600							12 x 2					
	700			LSC	-	-	2	12 x 5	S	L	1	-	
	800							12 x 10					

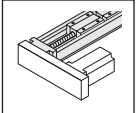
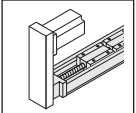
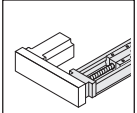
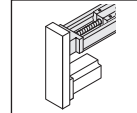
1) For length calculation, see chapter "Technical Data".
 2) See chapter "Lubrication and Maintenance". Lubrication version "LSC".
 3) Attachment kit also available without motor. When ordering, enter motor type "000".
 For attachment kits according to customer specifications, see chapter "Attachment Kits for Motors according to Customer Specifications".
 With servo motor attached, product only available as assembled in the chapter "Form of Delivery" (note position of motor connector).
 4) Use motors complying with the appropriate NEMA specification.
 Due to the varying journal dimensions for NEMA-specification motors, the attachment kit does not include a coupling.
 5) Permissible motor connector position (for "with motor" option only). For mechanical interface without motor: option code "000".
 6) For more information, see chapter "Switching System".

Version	Mounting interface ³⁾		Motor					Switching system ⁶⁾		Documentation
	Gear ratio	Mechanical interface	Motor code	Connection		Holding brake		Motor connector position ⁵⁾		
				1 cable	2 cables	with	without			
		F000								
F000 (without flange)	-	-	-	-	-	-	-	-		
		F001								
F001 (with flange)	i = 1.0	MSM019B	MSM019B-0300	-	2	Y	N		000	000 without sensor
		MSM031B	MSM031B-0300	-	2				090	
		MS2N03-B	MS2N03-B0BYN	1	-				180	
		NEMA 23-D ⁴⁾	-	-	-				270	
		S000								
		S090								
		S180								
		S270								
S000	i = 1.0	MSM019B	MSM019B-0300	-	2	Y	N		000	120 Sensor (PNP NC) 121 Sensor (NPN NC) 122 Sensor (PNP NO) 123 Sensor (NPN NO)
S090	i = 1.5								090	
S180	i = 1.0	MSM031B	MSM031B-0300	-	2				180	
S270	i = 1.5								270	
(with belt side drive)	i = 1.0	MS2N03-B	MS2N03-B0BYN	1	-				with cable duct, with switching cam for	
	i = 1.5								001 (without/with cover plate) 002 (with sealing strip)	

Flange	Motor connector position			
	0°	90°	180°	270°
F001	000	090 ★	180	270

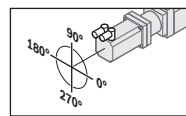

Example:
Flange F001
Motor connector position 90°

Belt side drive	Motor connector position			
	0°	90°	180°	270°
S000	-	090	180 ★	270
S090	000	090 ★	180	-
S180	000 ★	090	-	270
S270	000	-	180	270 ★

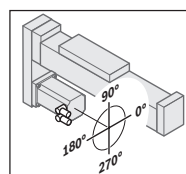

Example:
Timing belt side drive S270
Motor connector position 180°

★ Standard delivery (connector position)

PSK-090-NN-2 Configuration and ordering

Accuracy class	Length ¹⁾	Reference edge		Lubrication ²⁾	Cover			Drive	Carriage					
		Left	Right		without	with cover plate	with sealing strip		BASA d ₀ x P	Standard	Long	Quantity		
N = normal class P = precision class	340			LSS				16 x 5						
	440				0	1		16 x 10	S	L	1	2		
	540			LPG				16 x 16						
	640	L	R											
P	740			LCF				16 x 5						
	840				-	-	2	16 x 10	S	L	1	-		
	940			LSC				16 x 16						

¹⁾ For length calculation, see chapter "Technical Data".

²⁾ See chapter "Lubrication and Maintenance". Lubrication version "LSC".

³⁾ Attachment kit also available without motor. When ordering, enter motor type "000".

For attachment kits according to customer specifications, see chapter "Attachment Kits for Motors according to Customer Specifications".



With servo motor attached, product only available as assembled in the chapter "Form of Delivery" (note position of motor connector).

⁴⁾ Use motors complying with the appropriate NEMA specification.

Due to the varying journal dimensions for NEMA-specification motors, the attachment kit does not include a coupling.

⁵⁾ Permissible motor connector position (for "with motor" option only). For mechanical interface without motor: option code "000".

⁶⁾ For more information, see chapter "Switching System".

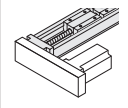
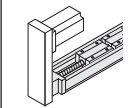
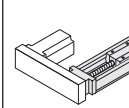
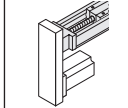
Version	Mounting interface ³⁾		Motor					Switching system ⁶⁾		Documentation
	Gear ratio	Mechanical interface	Motor code	Connection		Holding brake		Motor connector position ⁵⁾		
				1 cable	2 cables	with	without			
		F000								
F000 (without flange)	-	-	-	-	-	-	-	-		
		F001								
F001 (with flange)	i = 1.0	MSM031C	MSM031C-0300	-	2	Y	N	000 090 180 270	000 without sensor	000 without cable duct, without switching cam
		MSM041B	MSM041B-0300	-	2					
		MS2N03-B	MS2N03-B0BYN	1	-					
		MS2N03-D	MS2N03-D0BYN	1	-					
		MS2N04	MS2N04-C0BTN	1	-					
		NEMA 23-D ⁴⁾	-	-	-					
										
S000									120 Sensor (PNP NC) 121 Sensor (NPN NC) 122 Sensor (PNP NO) 123 Sensor (NPN NO)	with cable duct, with switching cam for 001 (without/with cover plate) 002 (with sealing strip)
S090	i = 1.0	MSM031C	MSM031C-0300	-	2	Y	N	000 090 180 270		
S180	i = 1.5	MSM041B	MSM041B-0300	-	2					
S270	i = 1.0	MS2N03-D	MS2N03-D0BYN	1	-					
(with belt side drive)	i = 1.5	MS2N03-B	MS2N03-B0BYN	1	-					
	i = 1.0	MS2N04	MS2N04-C0BTN	1	-					
	i = 1.5	MS2N04	MS2N04-B0BTN	1	-					

- 001 standard report
- 002 friction torque
- 003 lead deviation
- 004 travel accuracy
- 005 positional uncertainty

Flange	Motor connector position			
	0°	90°	180°	270°
F001	000	090 ★	180	270

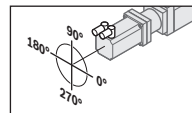

Example:
Flange F001
Motor connector position 90°

Belt side drive	Motor connector position			
	0°	90°	180°	270°
S000	-	090	180 ★	270
S090	000	090 ★	180	-
S180	000 ★	090	-	270
S270	000	-	180	270 ★

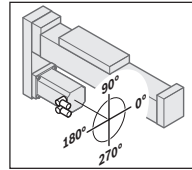

Example:
Timing belt side drive S270
Motor connector position 180°

★ Standard delivery (connector position)

PSK without cover

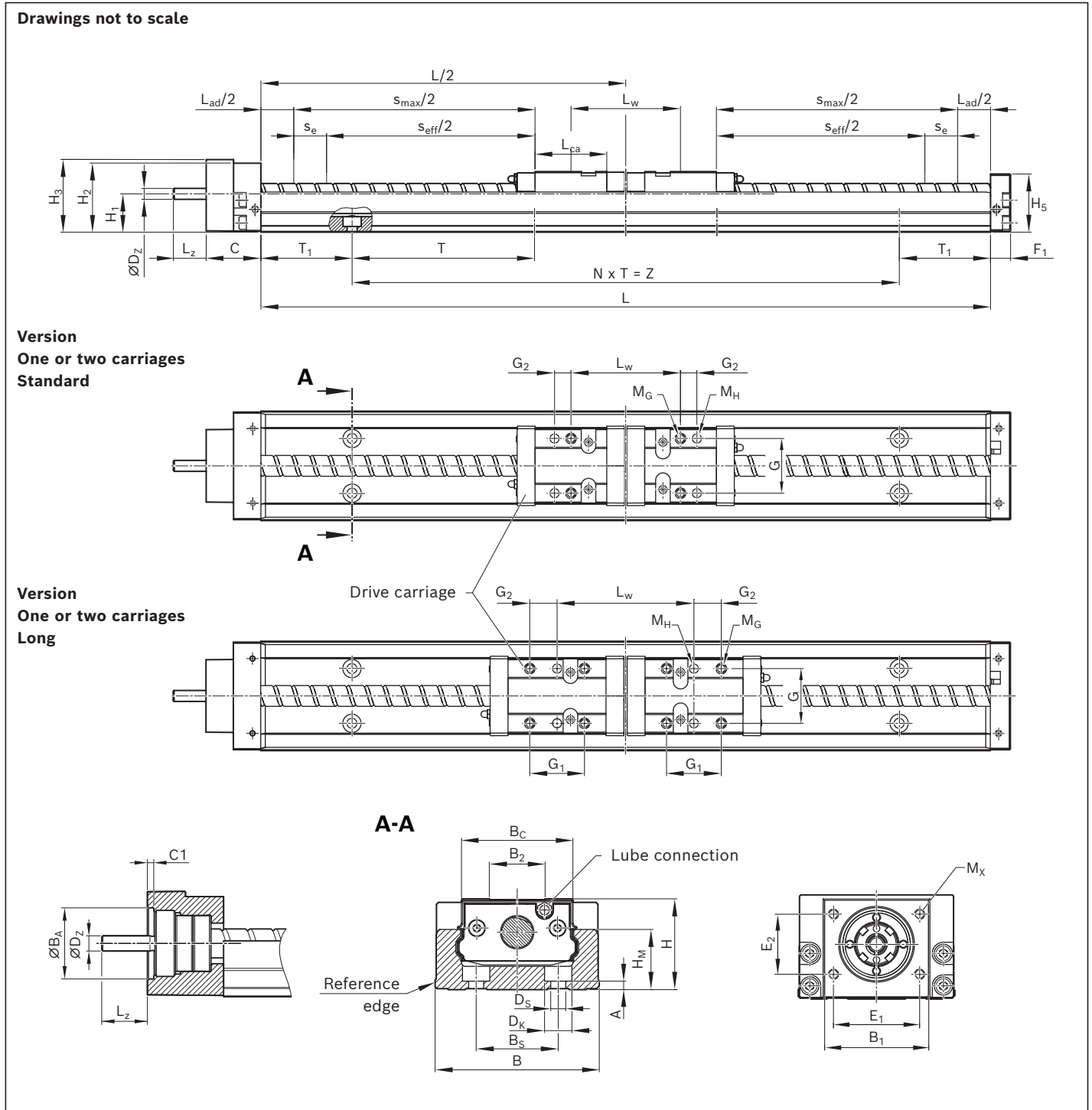

PSK	Dimensions (mm)																												
	A	B	B ₁	B ₂		$\varnothing B_A$	H7	B _C		B _S	C	C ₁	$\varnothing D_K$	$\varnothing D_S$	$\varnothing D_Z$	h7	E ₁	E ₂	F ₁	G		G ₁	G ₂		H	H ₁			
				Cover without	Cover with			Cover without	Cover with												Cover without	Cover with	Carriage Standard	Carriage Long					
050	2.5	50	32.8	6	47	25	33.7	62	25	28.5	2.5	8	4.5	5	23	23	10	25	55	30	-	15	26	16					
060	3.1	60	40.0	20	62	28	40.7	86	30	30.0	2.5	10	5.5	6	33	23	11	30	74	30	9	15	33	21					
090	4.5	86	54.5	33	88	40	59.4	112	46	38.0	2.5	11	6.5	9	40	28	13	46	100	46	15	23	46	29					

PSK with cover plate

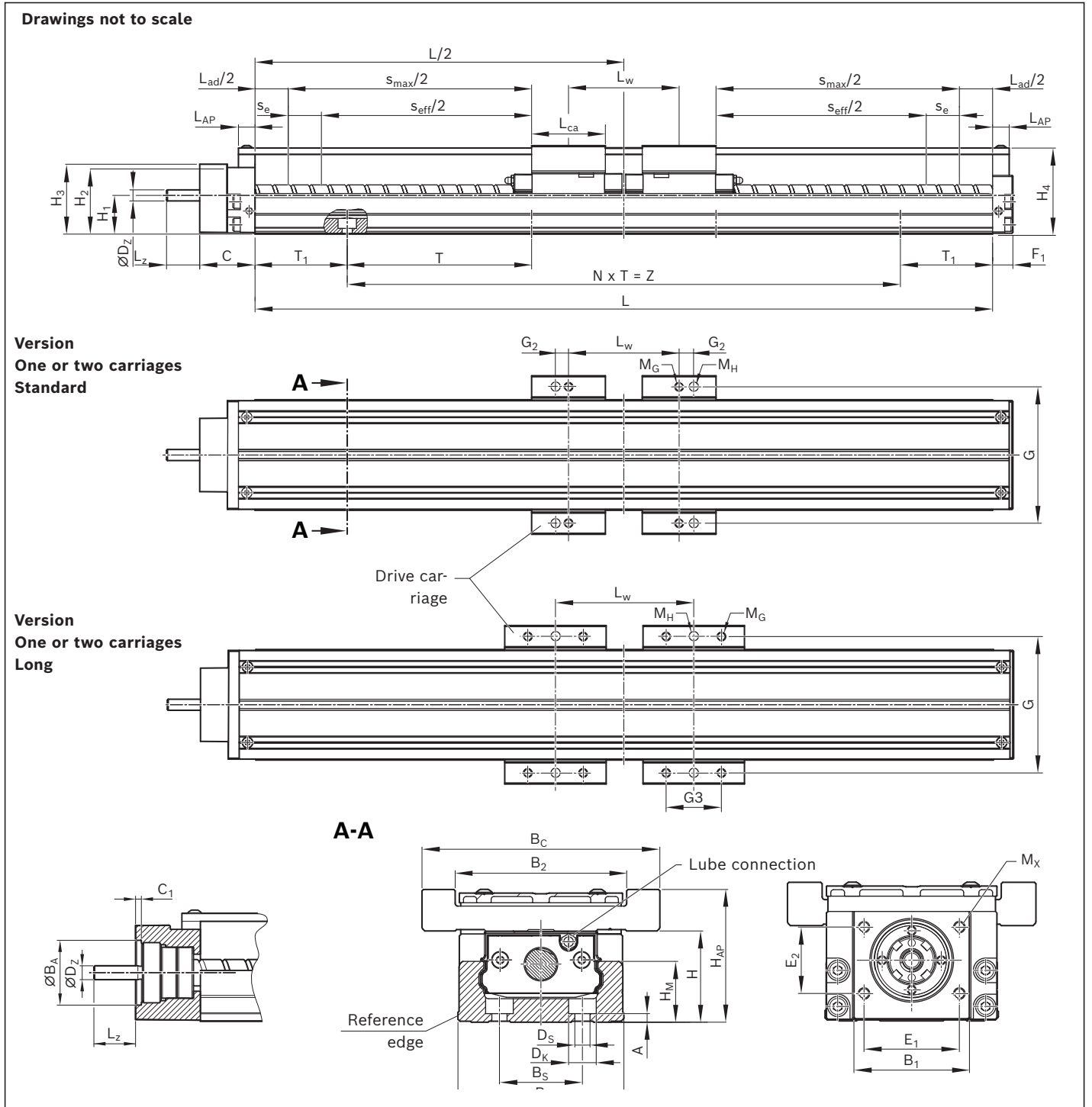

H ₂	H ₃	H ₄	H ₅	H _{AP}	H _M	L _{AP}	L _{ca}				L _w min		L _z	Cover		M _G	M _H	M _X	T	T ₁
							Carriage		Cover		Standard	Long		without	with					
							Standard	Long	Standard	Long										
29.2	31.0	37.5	25.5	40	19	9.0	-	39.3	-	60	15	M4-6.0 deep	M4-14 deep	Ø4 ^{H7-5} deep	M3-8 deep	80				
37.9	37.9	46.7	31.9	48	22	9.0	39.3	53.7	40	60	75	M5-8.5 deep	M5-15 deep	Ø5 ^{H7-8} deep	M4-8 deep	100				
51.5	51.2	65.0	44.0	68	30	12.5	57.9	79.6	60	90	110	M6-9.0 deep	M6-22 deep	Ø6 ^{H7-8} deep	M6-12 deep	100				

see chapter "Fastening"

PSK with sealing strip

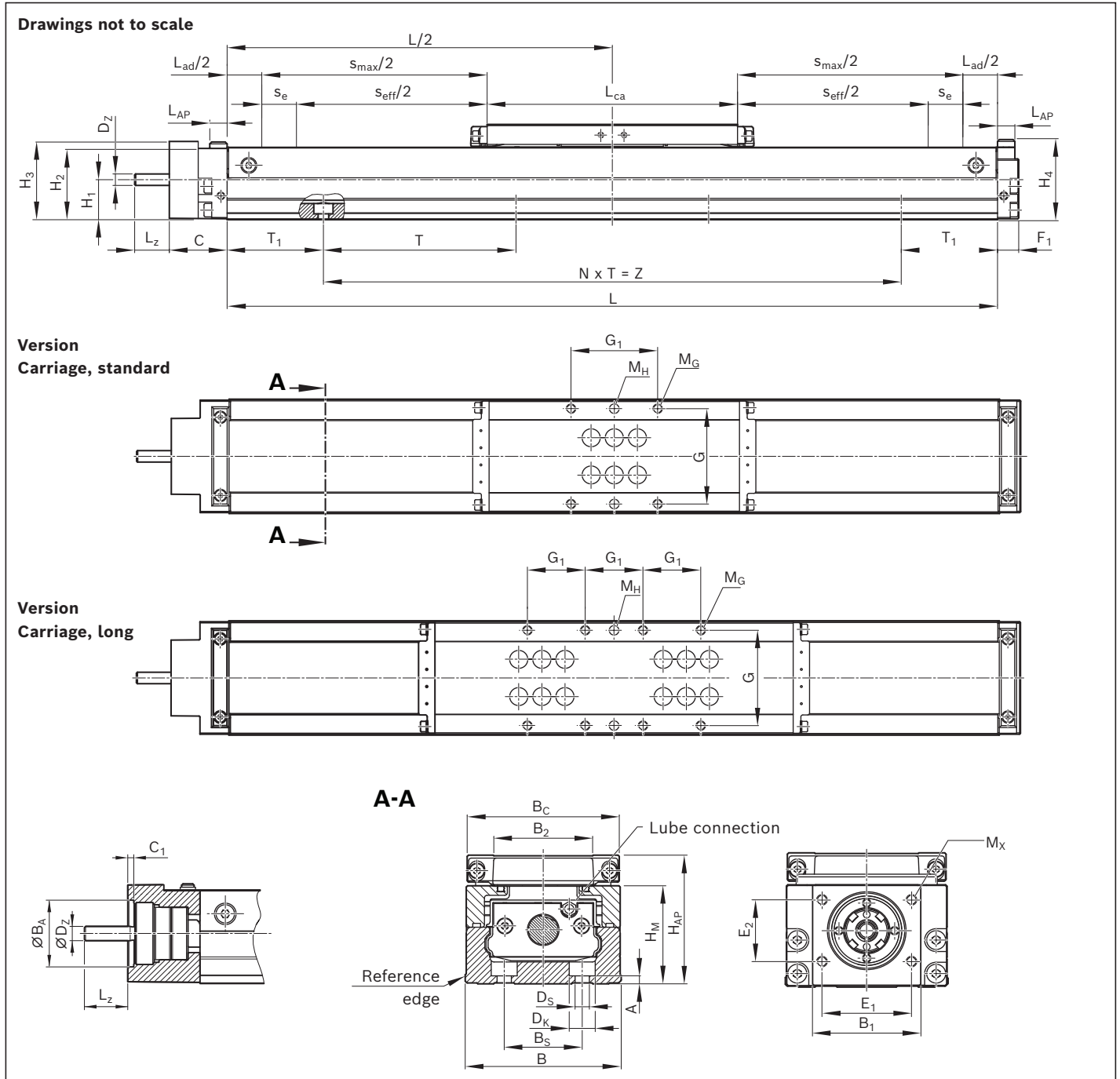

PSK	Dimensions (mm)																	
	A	B	B ₁	B ₂	ØB _A H7	B _C	B _S	C	C ₁	ØD _K	ØD _S	ØD ₂ h7	E ₁	E ₂	F ₁	G	G ₁	
																	Carriage	
																	Standard	Long
050	2.5	50	32.8	-	25	49.0	25	28.5	2.5	8	4.5	5	23	23	10	40	25	25
060	3.1	60	40.0	38	28	58.5	30	30.0	2.5	10	5.5	6	33	23	11	50	45	30
090	4.5	86	54.5	48	40	84.0	46	38.0	2.5	11	6.5	9	40	28	13	65	60	40

	H ₁	H ₂	H ₃	H ₄	H _{AP}	H _M	L _{AP}	L _{ca} Carriage		L _Z	M _G	M _H	M _X	T	T ₁
								Standard	Long						
	16	29.2	31.0	29.4	40	19	9	100	160	15	M4-9.7 deep	∅4 ^{H7} -5 deep	M3-8 deep	80	see chapter "Fastening"
	21	37.9	37.9	38.1	50	22	9	130	186	18	M5-10.5 deep	∅5 ^{H7} -8 deep	M4-8 deep	100	
	29	51.5	51.2	51.7	68	30	14	155	230	25	M6-15 deep	∅6 ^{H7} -8 deep	M6-12 deep	100	

Motor attachments with flange and coupling

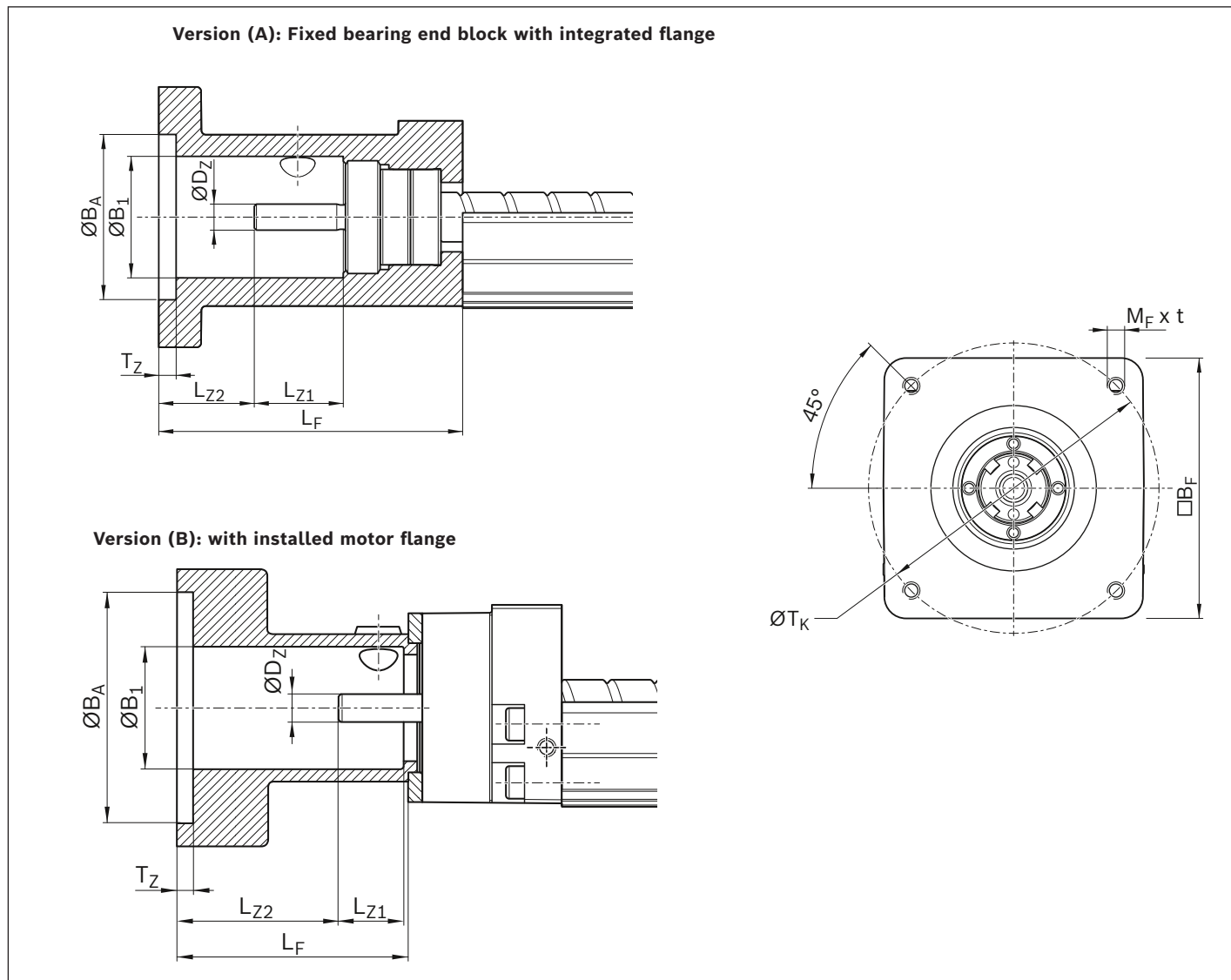

PSK	Motor	Dimensions (mm)											
		ØBA H7	ØB1	BF	ØDz h7	LF (A)	LF (B)	LZ1	LZ2	MF	t	ØTK	TZ
050	MSM019B	30	26.0	42	5	70.0	-	17.5	26.5	M3	7	45.00	4.0
	MSM031B	50	26.5	60	5	-	52.0	12.5	37.0	M4	9	70.00	4.0
	MS2N03-B	40	26.5	54	5	-	52.0	12.5	37.0	M4	9	63.00	3.5
	NEMA 17-C ¹⁾	22	26.0	42	5	65.0	-	17.5	21.5	Ø3.3	8	43.80	4.0
060	MSM019B	30	28.0	40	6	75.0	-	20.5	27.0	M3	7	45.00	4.0
	MSM031B	50	26.5	60	6	-	50.0	17.0	32.0	M4	10.5	70.00	3.5
	MS2N03-B	40	28.0	60	6	70.0	-	20.5	22.0	M4	10	63.00	4.0
	NEMA 23-D	38.1	28.0	60	6	70.0	-	20.5	22.0	M4	10	66.68	4.0
090	MSM031C	40	39.0	60	9	103.0	-	27.0	40.0	M4	8	70.00	4.0
	MSM041B	70	42.0	80	9	-	83.0	25.0	58.0	M5	15	90.00	3.5
	MS2N03	40	39.0	60	9	103.0	-	27.0	40.0	M4	10	63.00	4.0
	MS2N04	50	37.0	82	9	-	77.5	25.0	52.5	M6	11	95.00	3.0
	NEMA 23-D	38.1	39.0	60	9	103.0	-	27.0	40.0	M4	10	66.68	4.0

¹⁾ Due to the varying journal dimensions for NEMA-specification motors, the attachment kit does not include a coupling. M_F Ø3.3mm as drill hole

Motor attachments with belt side drive

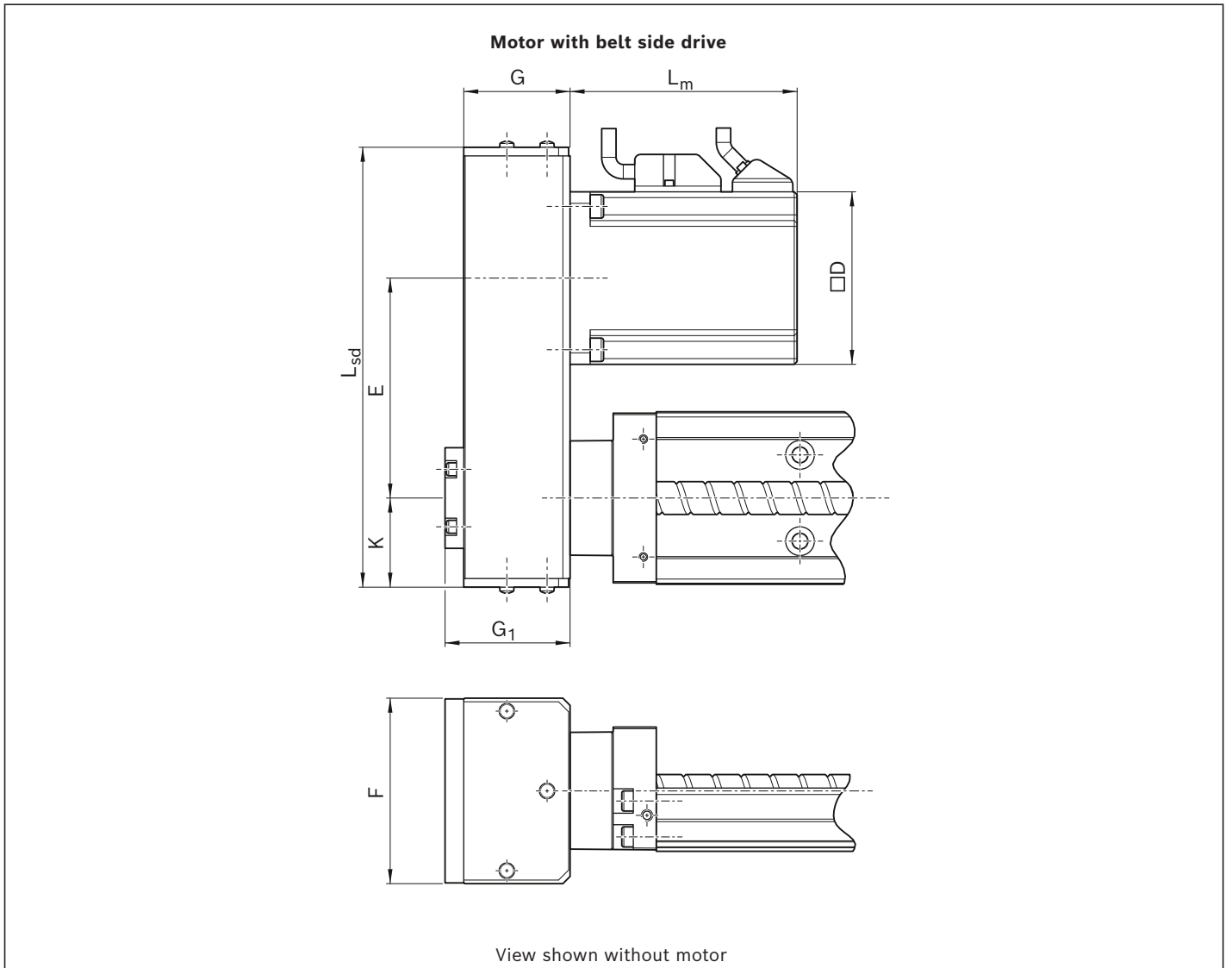

PSK	Motor	Dimensions (mm)										L _m	
		D	E i = 1	E i = 1.5	F	G	G ₁	K	L _{sd} i = 1	L _{sd} i = 1.5	with brake	without brake	
050	MSM019B	38	76.5	76.5	48.0	27.5	29.0	27.5	139	139.0	See motor dimension drawings		
	MSM019B	38	76.5	76.5	48.0	27.5	29.0	27.5	139	139.0			
060	MSM031B	60	78.0	75.0	64.5	37.0	43.5	33.5	154	154.0			
	MS2N03-B	54	78.0	75.0	64.5	37.0	43.5	33.5	154	154.0			
090	MSM031C	60	103.5	115.0	64.5	37.0	43.5	33.5	180	191.5			
	MSM041B	80	122.0	122.0	88.0	51.0	57.0	45.5	231	231.0			
	MS2N03	54	103.5	115.0	64.5	37.0	43.5	33.5	180	191.5			
	MS2N04	80	122.0	122.0	88.0	51.0	57.0	45.5	231	231.0			

Motor attachment kits according to customer specification

The motor attachment for linear motion systems with Rexroth ball screw assembly consists of either an attachment kit with flange and coupling (MF) or a belt side drive (SD).

The available combinations are shown in the "Configuration and ordering" selection tables for each size. In addition to motor attachment kits for Rexroth motors, attachment kits for motors according to customer specification can also be ordered. In order to determine the appropriate attachment kit, the connection geometry of the motor is crucial. Characteristics required to clearly determine motor geometry are shown below.

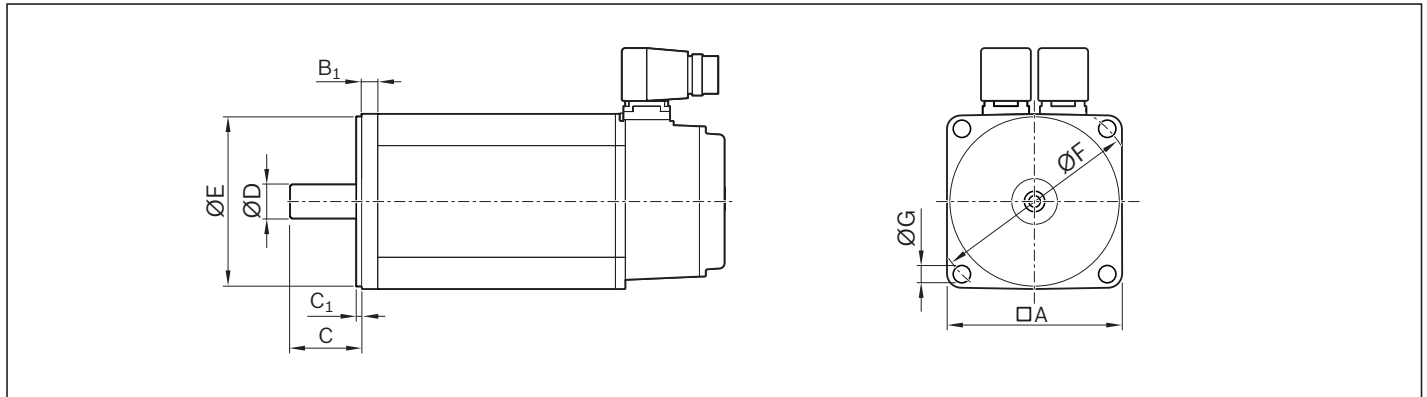

The dimensions queried result in a unique "motor geometry code":

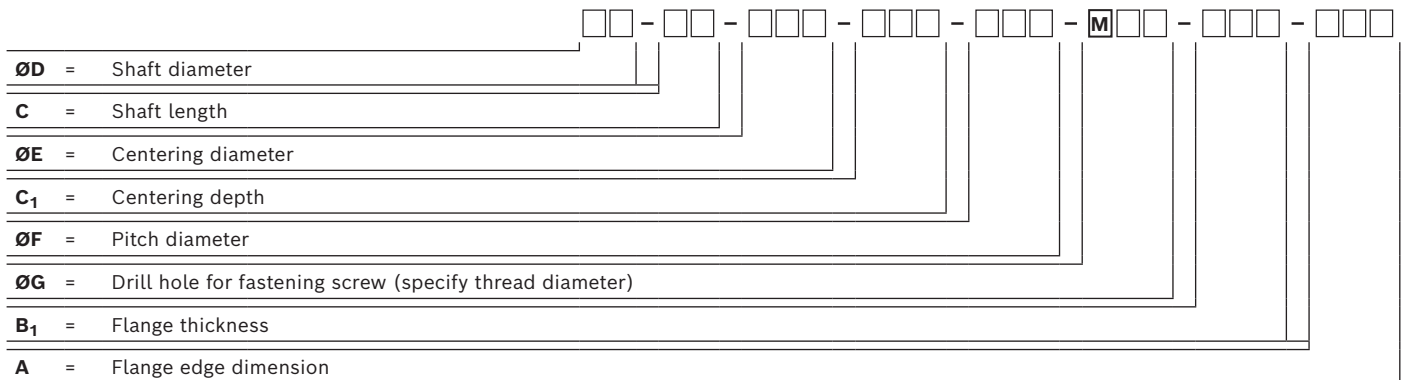

Example of servo motor IndraDyn S type MS2N04

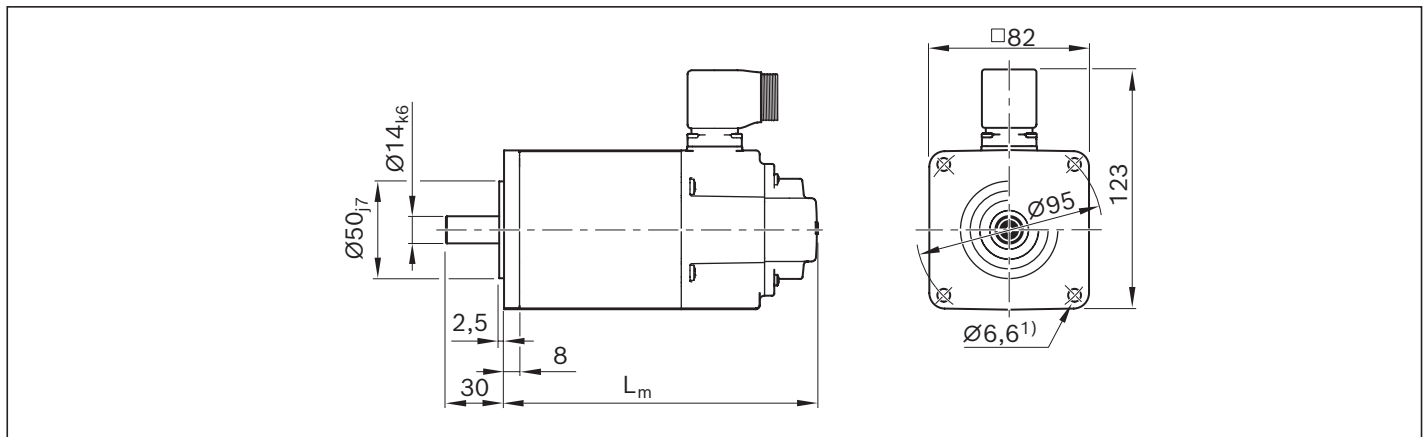

1 4 - 3 0 - 0 5 0 - 2 . 5 - 0 9 5 - M 0 6 - 0 0 8 - 0 8 2

¹⁾ The drill hole $\text{Ø} 6.6$ mm results in the type designation M06 for the geometry motor code (nominal thread diameter of mounting screw M6).

Motor attachment kits for motors according to customer specification can be selected using the online configurator in the eShop. To do this, select the "mechanical interface" and "motors according to customer specification" option.

Size of customer motor

Motor manufacturer ▼

Motor type ▼

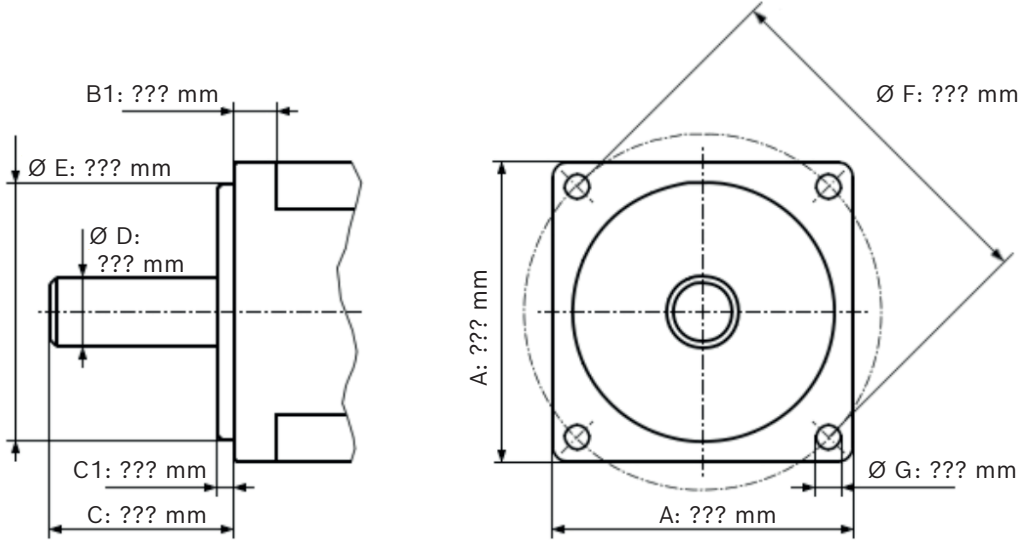

The technical drawing shows two views of a motor attachment kit. The left view is a side profile showing dimensions: B1 (width of the top flange), Ø E (outer diameter of the main body), Ø D (inner diameter of the shaft), C1 (width of the bottom flange), and C (total width). The right view is a top-down view showing a square mounting plate with a central circular opening. Dimensions include A (square side length), Ø F (outer diameter of the mounting plate), and Ø G (diameter of the mounting holes).

Example

Size of customer motor

Motor manufacturer ▼

Motor type ▼

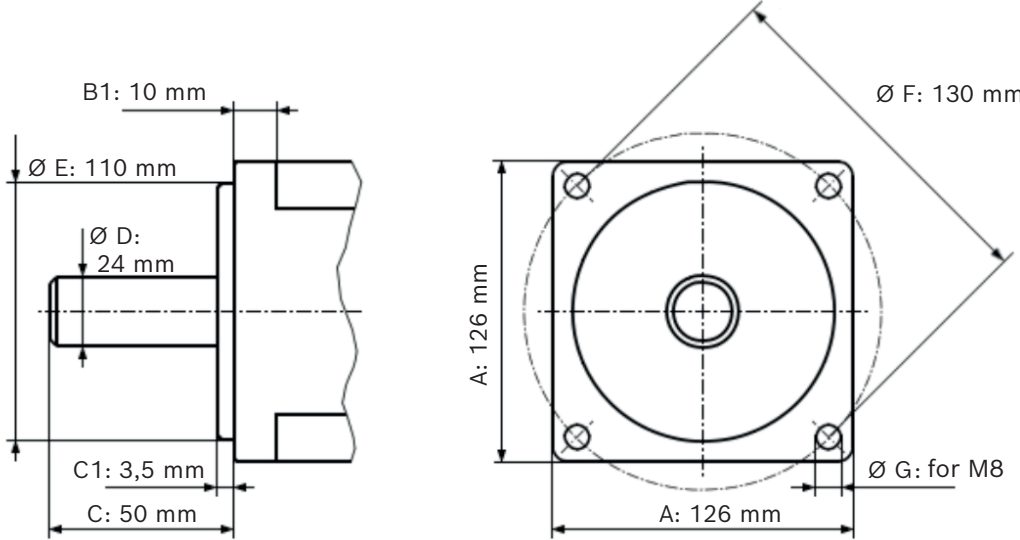

The example technical drawing shows the same motor attachment kit with specific dimension values: B1: 10 mm, Ø E: 110 mm, Ø D: 24 mm, C1: 3,5 mm, C: 50 mm, A: 126 mm, Ø F: 130 mm, and Ø G: for M8.

IndraDyn S Synchronous Motor MSM

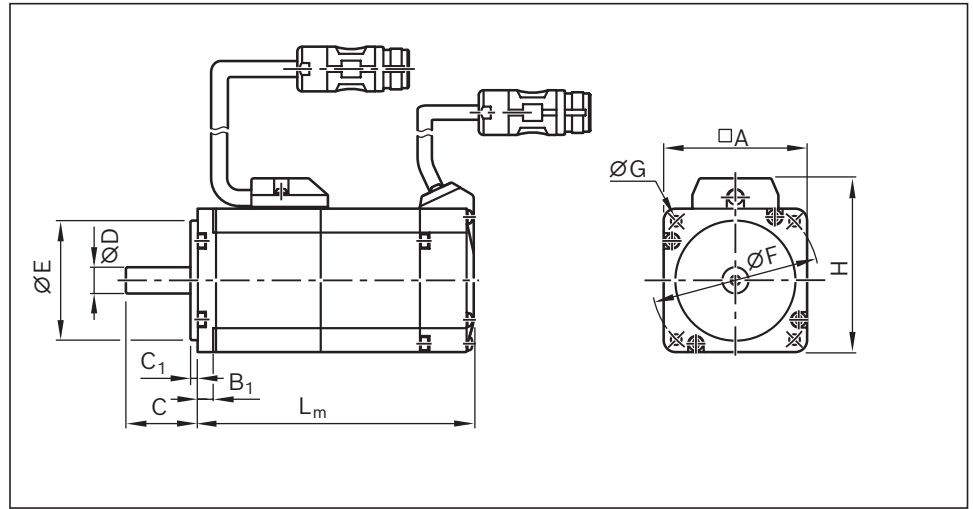

Motor representation, schematic

Dimensions / motor data

Motor code ¹⁾	Dimensions (mm)										L _m	
	□A	B ₁	C	C ₁	∅ D _{h6}	∅ E _{h7}	∅ F	∅ G	H	Brake without	with	
MSM 019B-0300	38	6.0	25	3	8	30	45	3.4	51	92.0	122.0	
MSM 031B-0300	60	6.5	30	3	11	50	70	4.5	73	79.0	115.5	
MSM 031C-0300	60	6.5	30	3	14	50	70	4.5	73	98.5	135.0	
MSM 041B-0300	80	6.0	35	3	19	70	90	6.0	93	112.0	149.0	

¹⁾ from the "Configuration and ordering" table

Version:

- ▶ Plain shaft without shaft seal
- ▶ M5 multi-turn absolute encoder (20-bit, absolute encoder function only available with backup battery)
- ▶ Cooling system: natural convection
- ▶ IP54 enclosure protection class (shaft: IP40)
- ▶ With and without brake
- ▶ M17 metal round connector

Notes:

Motors are available with controllers and control units. For further motor types and more information on motors, controllers and control units, please refer to the Rexroth catalogs on drive technology at www.boschrexroth.com/mediadirectory.

Motor data									Motor connection (cable)	Brake	Type code	Material number
n_{\max} (min ⁻¹)	M_0 (Nm)	M_{\max} (Nm)	M_{br} (Nm)	J_m (kg/m ²)	J_{br} (kg/m ²)	m_m (kg)	m_{br} (kg)					
5 000	0.32	0.95	0.29	0.0000051	0.0000002	0.47	0.21		2	N	MSM 019B-0300-NN-M5-MH0	R911344211
										Y	MSM 019B-0300-NN-M5-MH1	R911344212
5 000	0.64	1.91	1.27	0.0000140	0.0000018	0.82	0.48		2	N	MSM 031B-0300-NN-M5-MH0	R911344213
										Y	MSM 031B-0300-NN-M5-MH1	R911344214
5 000	1.30	3.80	1.27	0.0000260	0.0000018	1.20	0.50		2	N	MSM 031C-0300-NN-M5-MH0	R911344215
										Y	MSM 031C-0300-NN-M5-MH1	R911344216
4 500	2.40	7.10	2.45	0.0000870	0.0000075	2.30	0.80		2	N	MSM 041B-0300-NN-M5-MH0	R911344217
										Y	MSM 041B-0300-NN-M5-MH1	R911344218

IndraDyn S Synchronous Motor MS2N

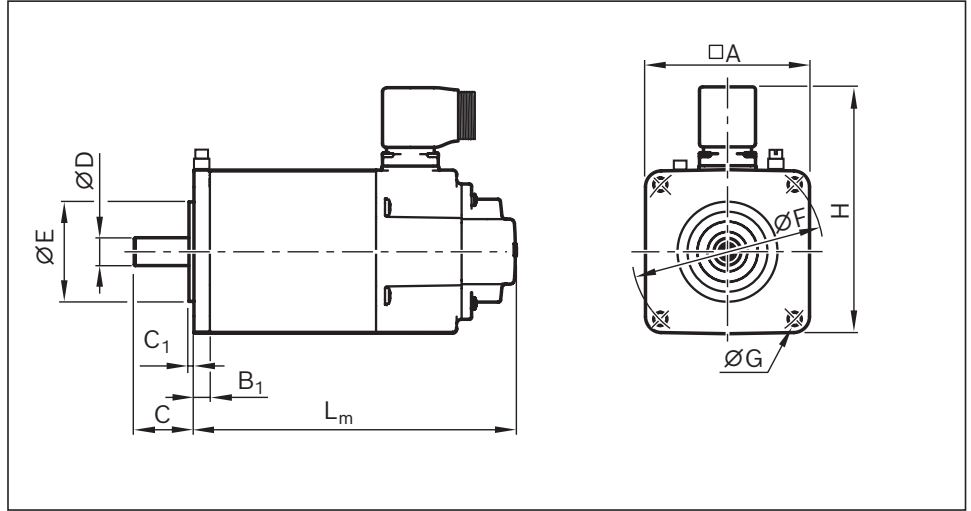
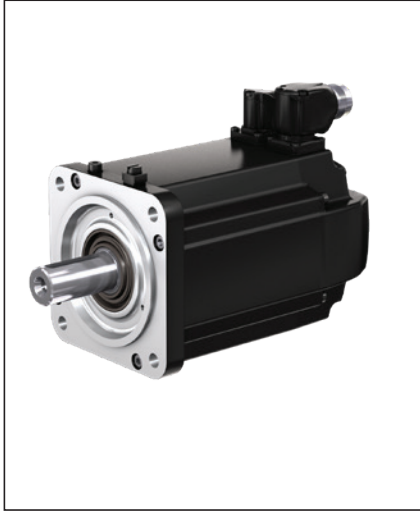

Motor representation, schematic

Dimensions / motor data

Motor code ¹⁾	Dimensions (mm)											
	$\square A$	B_1	C	C_1	$\varnothing D_{k6}$	$\varnothing E_{j6}$	$\varnothing F$	$\varnothing G$	Cables	H	Brake	L_m
									2	1	without	with
MS2N03-B0BYN	58	7.5	20	2.5	9	40	63	4.5	84	99	163	192
MS2N03-D0BYN	58	7.5	23	2.5	11	40	63	4.5	84	99	203	232
MS2N04-B0BTN	82	8	30	2.5	14	50	95	6.6	108	123	162	194.5
MS2N04-C0BTN	82	8	30	2.5	14	50	95	6.6	108	123	194	226.5

¹⁾ from the "Configuration and ordering" table

Version

- ▶ Plain shaft without shaft seal ring
- ▶ Multi-turn encoder
- ▶ Standard encoder (B) in conjunction with 2-cable connection (Hiperface interface)
- ▶ Advanced encoder (C) in conjunction with 1-cable connection (AcuroLink interface)
- ▶ IP64 enclosure protection class
- ▶ With and without brake
- ▶ Special ground connection terminal near motor flange (used as needed)

Notes:

Motors are available with controllers and control units. For further motor types and more information on motors, controllers and control units, please refer to the Rexroth catalogs on drive technology at www.boschrexroth.com/mediadirectory.

Motor data									Motor connection (cable)	Brake	Type code	Material number
n_{\max} (min ⁻¹)	M_0 (Nm)	M_{\max} (Nm)	M_{br} (Nm)	J_m (kg/m ²)	J_{br} (kg/m ²)	m_m (kg)	m_{br} (kg)					
9 000	0.73	3.46	1.8	0.000023	0.000007	1.4	0.4	1	N	MS2N03-B0BYN-CMSH0-NNNNE-NN	R911384767	
								1	Y	MS2N03-B0BYN-CMSH1-NNNNE-NN	R911384769	
9 000	1.15	6.8	1.8	0.000037	0.000007	2.0	0.4	1	N	MS2N03-D0BYN-CMSH0-NNNNE-NN	R911384772	
								1	Y	MS2N03-D0BYN-CMSH1-NNNNE-NN	R911384773	
6 000	1.75	5.9	5.0	0.000070	0.000040	2.7	0.7	1	N	MS2N04-B0BTN-CMSH0-NNNNE-NN	R911384527	
								1	Y	MS2N04-B0BTN-CMSH1-NNNNE-NN	R911384528	
6 000	2.80	12.0	5.0	0.000110	0.000050	3.7	0.7	1	N	MS2N04-C0BTN-CMSH0-NNNNE-NN	R911384531	
								1	Y	MS2N04-C0BTN-CMSH1-NNNNE-NN	R911384532	

Switch mounting

Switching system overview

Components (unassembled)

- 1 Sensor
- 2 Switching cam
- 3 Cable duct (aluminum alloy, black anodized)
- 4 Clamping element for cable duct
- 5 Sliding block
- 6 Set screw

Instructions for mounting

- ▶ A cable duct is required to install the sensors.
- ▶ **Mounting side:**
The sensors can be mounted on the left (L) or the right (R).
- ▶ For two-carriage versions:
Sensor actuation with switching cam on drive carriage (motor side).

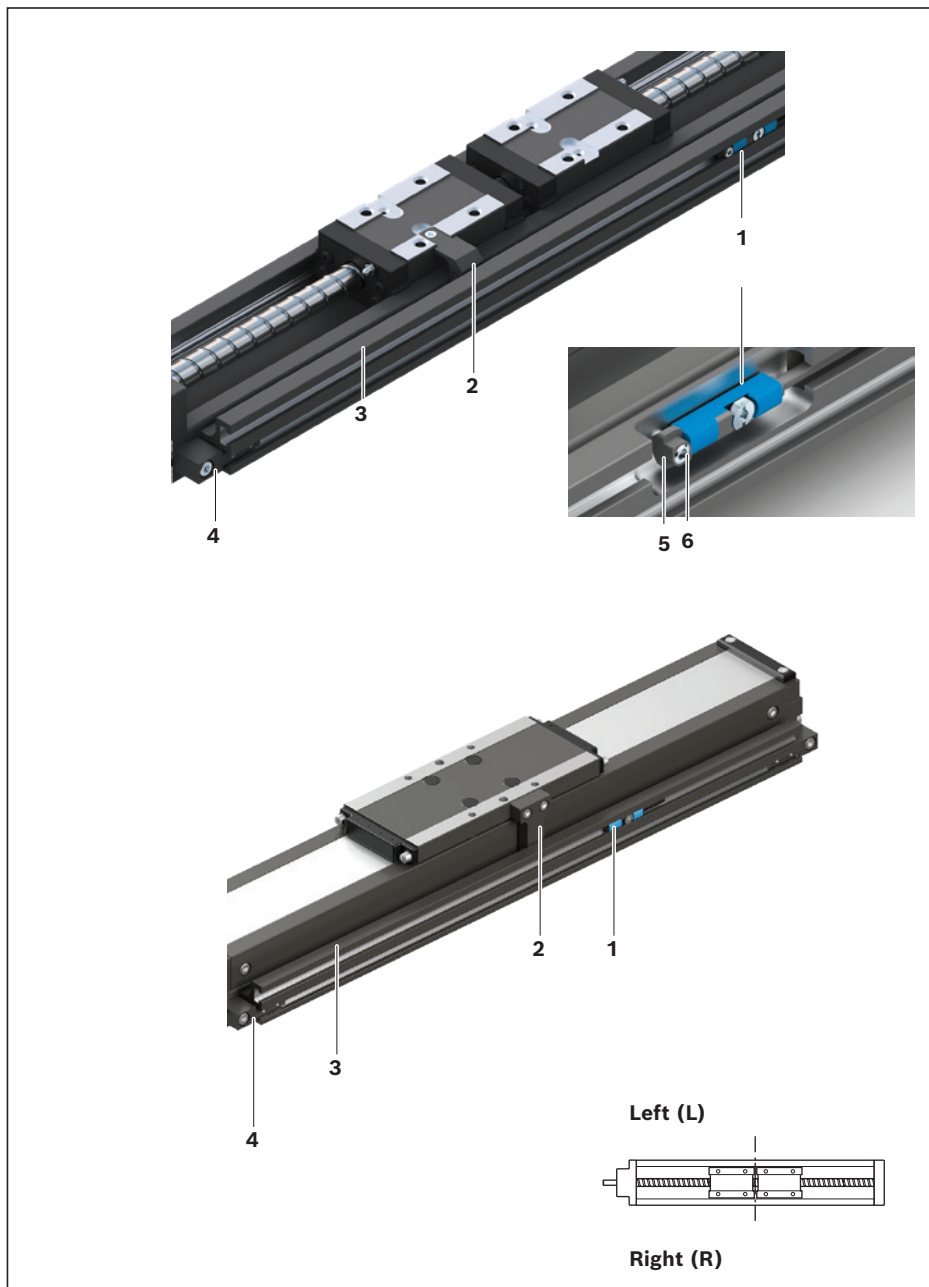

Cable duct

Function

- For mounting and fastening the sensors
- For cable routing

Instructions for mounting

- ▶ The cable duct is fastened to the end blocks of the precision module with clamping elements on the mounting side of the sensors.
- ▶ Fastening materials included in delivery.

Dimensions for cable duct

PSK	Dimensions (mm)						
	A	B	C	D	N ₁	N ₂	N ₃
050	17.75	8.50	13	24	5.20	5.90	8.20
060							
090							

Connecting dimensions

PSK	Dimensions (mm)			
	E	F	G	H
050	17.5	26	14.2	3.5
060	17.5	33	16.2	8.0
090	17.5	46	20.0	14.5

Sensor and attachments

Item	Description	Material numbers
1	Sensor	see chapter "Sensors"
2	Switching cam	
	PSK without / with cover plate	
	PSK-050	R141900084
	PSK-060	R141900085
	PSK-090	R141900086
	PSK with sealing strip	
	PSK-050	R141900087
	PSK-060	R141900088
	PSK-090	R141900089
3	Cable duct	R141901101 (L - 12 mm)
4	Clamping element	R141900083
5	Sliding block	R117509008
6	Set screw M4	R343700502

Cable duct

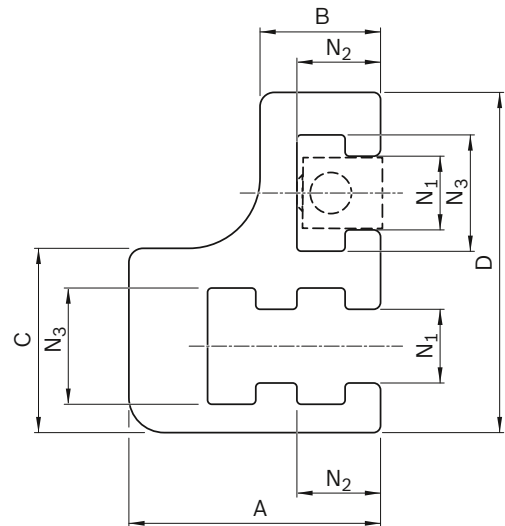

Arrangement of switching cam and cable duct

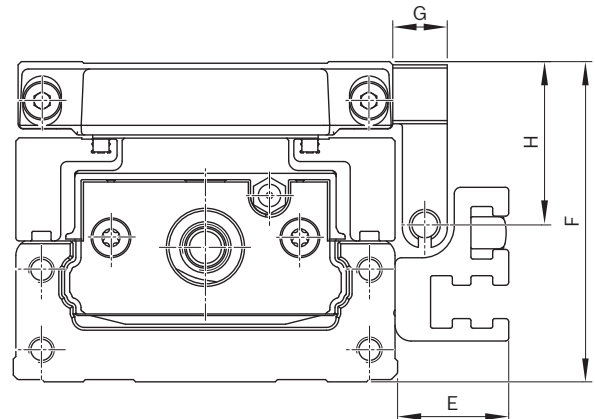
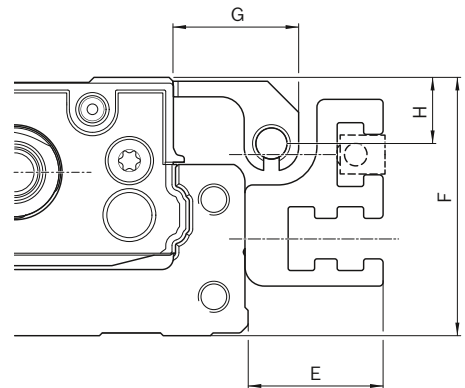

Sensors

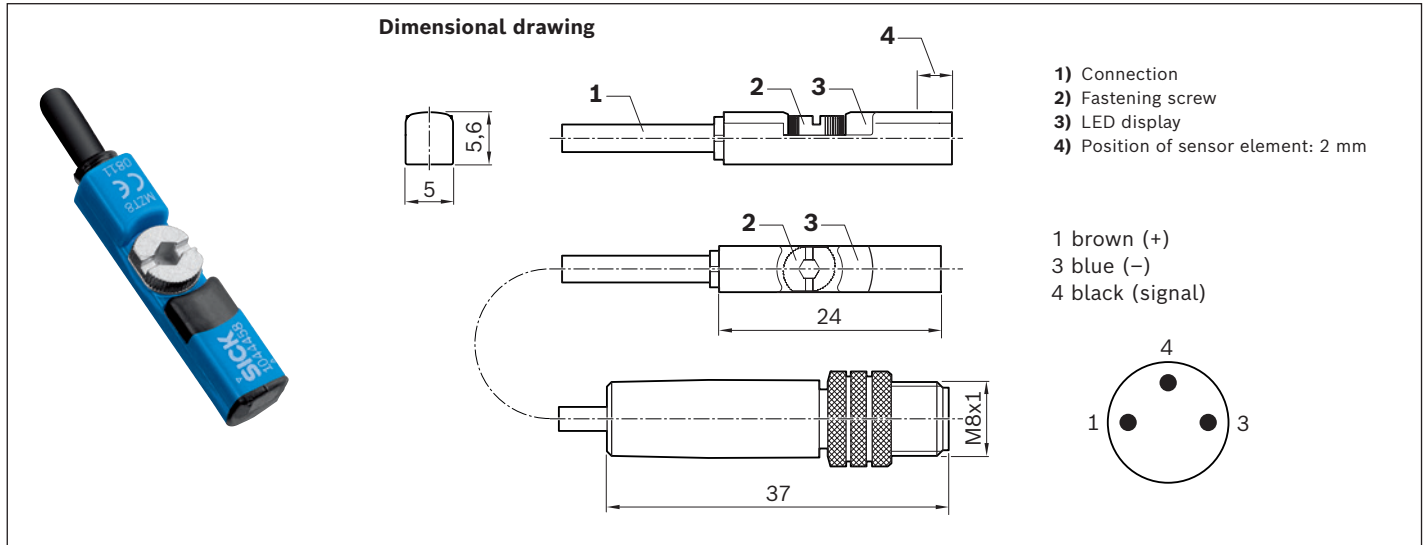

Magnetic sensor

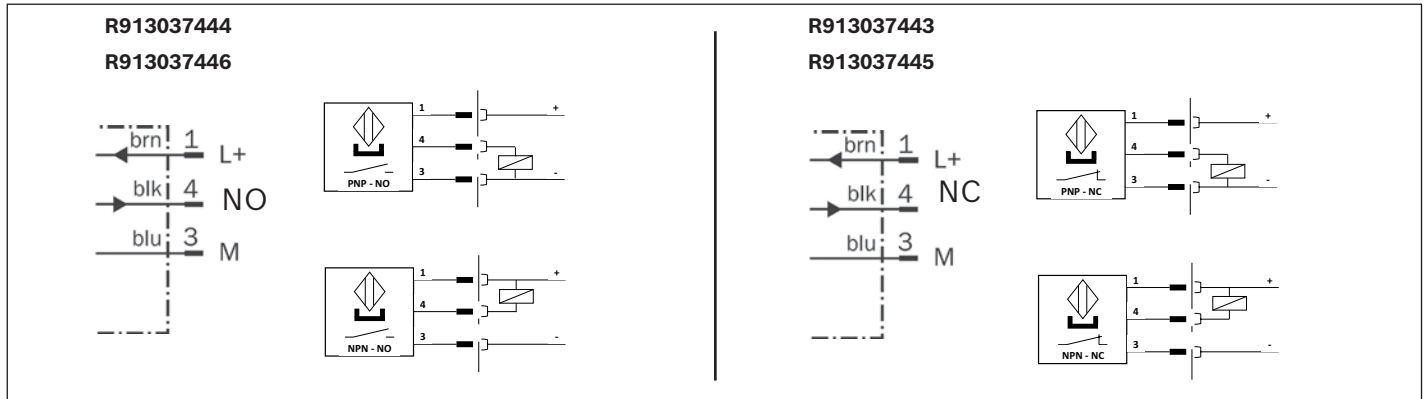

Connection diagram



Material numbers/technical data

Use	Limit switch	Reference switch	Limit switch	Reference switch
Material number	R913037445	R913037444	R913037443	R913037446
Designation	MZT8-03VPO-KRDS14	MZT8-03VPS-KRDS13	MZT8-03VNO-KRDS16	MZT8-03VNS-KRDS15
Functional principle	magnetic			
Operating voltage	10 - 30 VDC			
Load current	≤ 200 mA			
Switching function	PNP/NC	PNP/NO	NPN/NC	NPN/NO
Connection type	0.5 m cable and M8x1 plug, 3-pin with knurled screw connection			
Function indicator	✓			
Short-circuit protection	✓			
Reverse polarity protection	✓			
Switch-on suppression	✓			
Switching frequency	3 kHz			
Pulse elongation (off delay)	20 ms			
Max. permissible starting speed	5 m/s			
Suitable for drag chains*	✓			
Torsion-resistant*	✓			
Welding spark-resistant*	—			
Cable cross-section*	3x0.14 mm ²			
Cable diameter D*	2.9 ±0.15 mm			
Static bending radius*	≥ 5xD			
Dynamic bending radius*	≥ 10xD			
Bending cycles*	> 2 Mio.			
Max. permissible travel speed*	5 m/s			
Max. permissible acceleration*	≤ 5 m/s ²			
Ambient temperature	-30 °C bis +80 °C			
Protection class	IP68			
MTTFd (per EN ISO 13849-1)	MTTFd = 2339.0 years			
Certifications and approvals**	  			

*) Technical data for connection line (0.5 m) cast on magnetic sensor only. Available extension cables offer even more performance, e.g. for use in a cable drag chain (see below).

** No  certificate for import to the Chinese market required for these products. Document "Sales information CCC" available on request.

Extensions

Assembled on one end

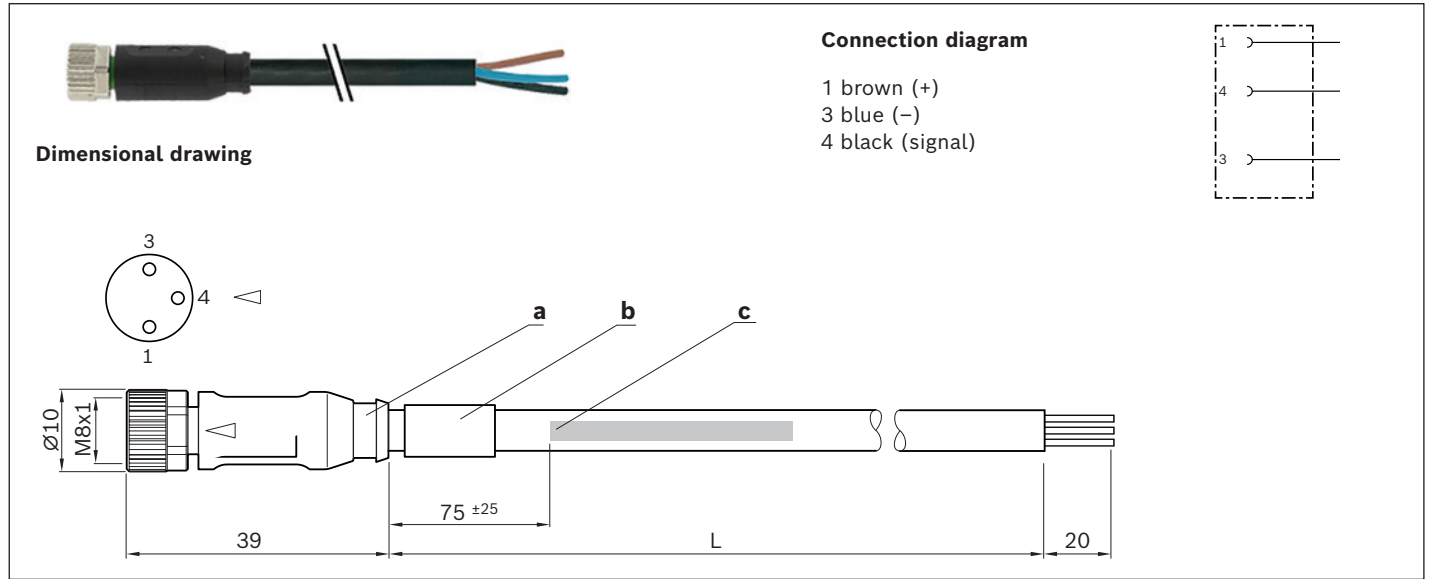



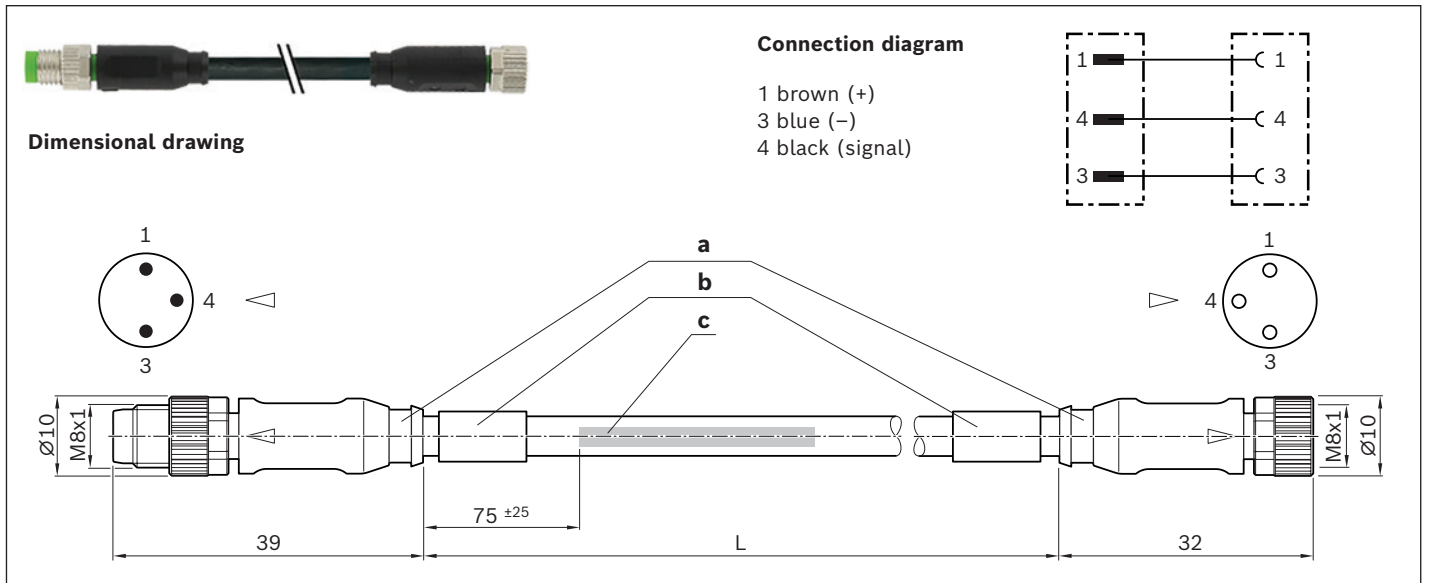

Material numbers

Use	Extension cable		
Material number	R911344602	R911344619	R911344620
Designation	7000-08041-6500500	7000-08041-6501000	7000-08041-6501500
Length (L)	5.0 m	10.0 m	15.0 m
Connection type 1	Female connector, straight, M8x1, 3-pin		
Connection type 2	Unassembled cable end		

Assembled on two sides

Material numbers

Use	Extension cable				
Material number	R911344621	R911344622	R911344623	R911344624	R911344625
Designation	7000-88001-6500050	7000-88001-6500100	7000-88001-6500200	7000-88001-6500500	7000-88001-6501000
Length (L)	0.5 m	1.0 m	2.0 m	5.0	10.0
Connection type 1	Female connector, straight, M8x1, 3-pin				
Connection type 2	Connector, straight, M8x1, 3-pin				

Technical data for extensions pre-assembled on one or two sides

Function indicator	-
Operating voltage indicator	-
Operating voltage	10 - 30 VDC
Type of cable	PUR black
Suitable for drag chains	✓
Torsion-resistant	✓
Weld spark-resistant	✓
Cable cross-section	3x0.25 mm ²
Cable diameter D	4.1 ±0.2 mm
Static bending radius	≥ 5xD
Dynamic bending radius	≥ 10xD
Bending cycles	> 10 mil.
Max. permissible travel speed	3.3 m/s for 5 m travel range (typ.), up to 5 m/s for 0.9 m travel range
Max. permissible acceleration	≤ 30 m/s ²
Ambient temperature fixed ext.	-40 °C to +85 °C
Ambient temperature flexible ext.	-25 °C to +85 °C
Protection class	IP68
Certifications and approvals	    

a) Contour for 6.5 mm corrugated tube (inner diameter)



b) Cable grommet

c) Cable printing per printing specification

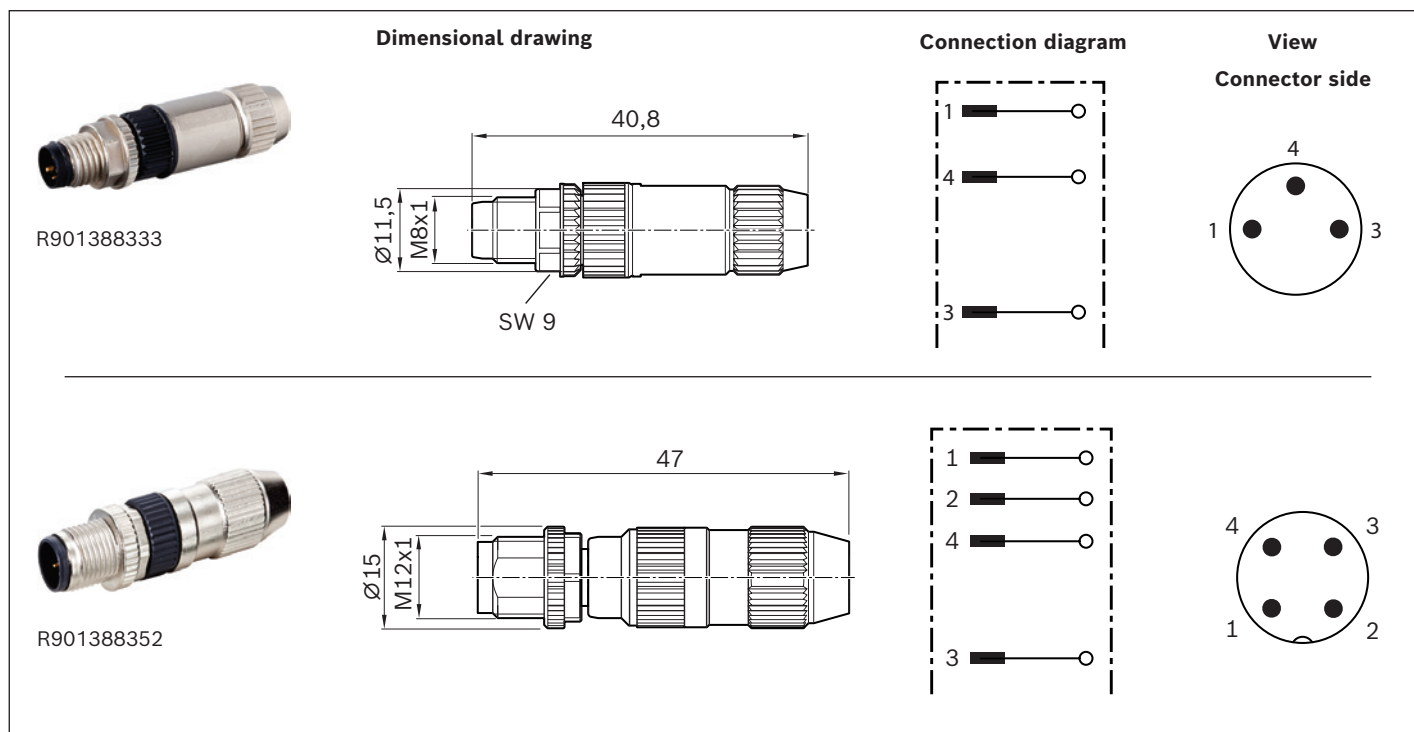
Connectors





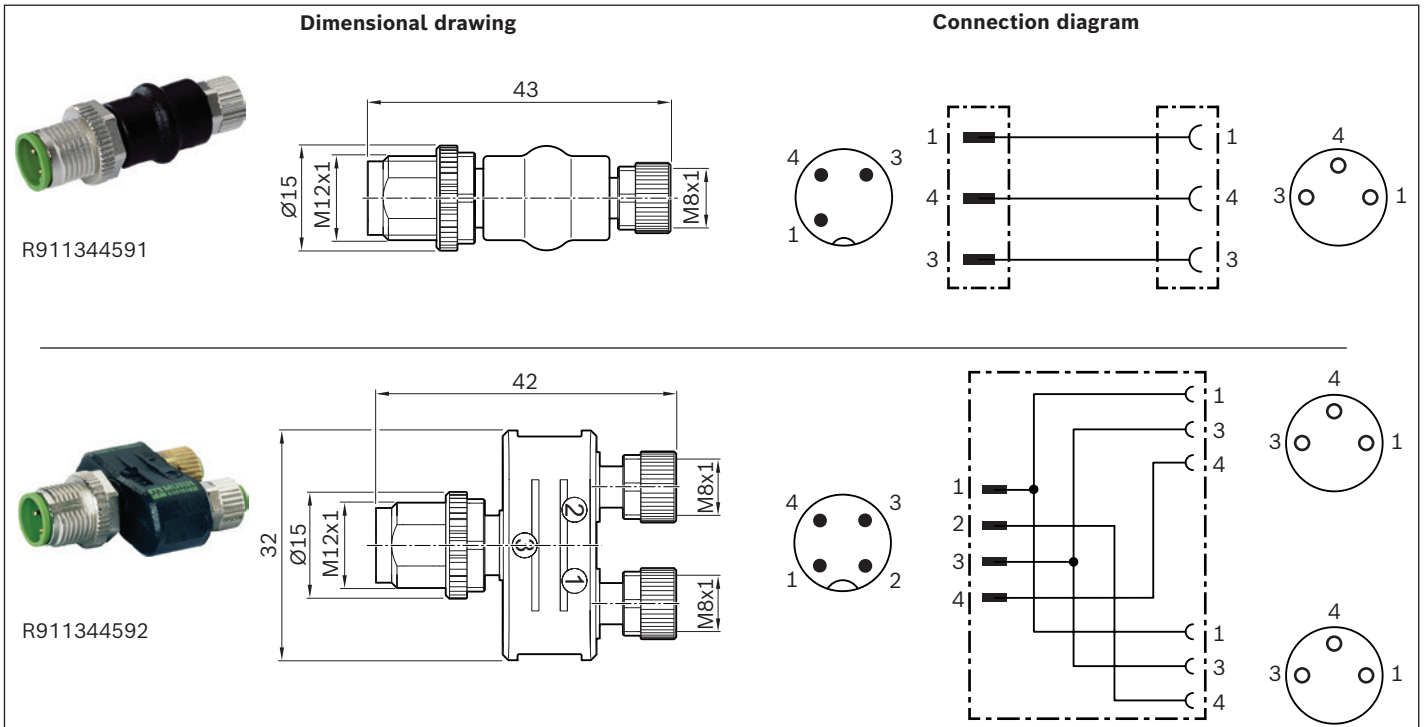

Material numbers/technical data

Use	Connector, single	
Material number	R901388333	R901388352
Designation	7000-08331-0000000	7000-12491-0000000
Version	straight	
Operating current per contact	max. 4 A	
Operating voltage	max. 32 V AC/DC	
Connection type	Straight plug, M8x1, 3-pin, IDC, self-locking screw	Straight plug, M12x1, 4-pin, IDC, self-locking screw
Function indicator	-	
Operating voltage indicator	-	
Connection cross-section	0.14...0.34 mm ²	
Ambient temperature	-25 °C to +85 °C	
Protection class	IP67 (inserted and screwed down)	
Certifications and approvals	  	

Adapters





Material numbers/technical data

Use	Adapters	
Material number	R911344591	R911344592
Designation	7000-42201-0000000	7000-41211-0000000
Version	straight	
Operating current per contact	max. 4 A	
Operating voltage	max. 32 V AC/DC	
Connection type 1	Straight female connector, M8x1, 3-pin, self-locking screw thread	2 X straight female connectors, M8x1, 3-pin, self-locking screw thread
Connection type 2	Male connector, straight, M12x1, 3-pin, self-locking screw thread	Straight plug, M12x1, 4-pin, IDC, self-locking screw thread
Function indicator	-	
Operating voltage indicator	-	
Connection cross-section	-	
Ambient temperature	-25 °C to +85 °C	
Protection class	IP67 (inserted and screwed down)	
Certifications and approvals		  

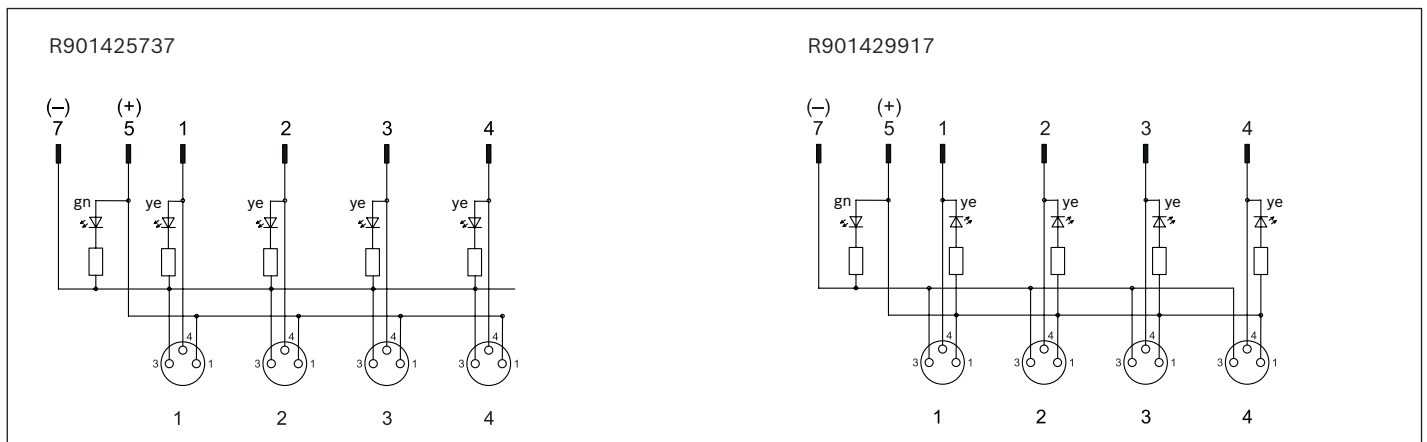
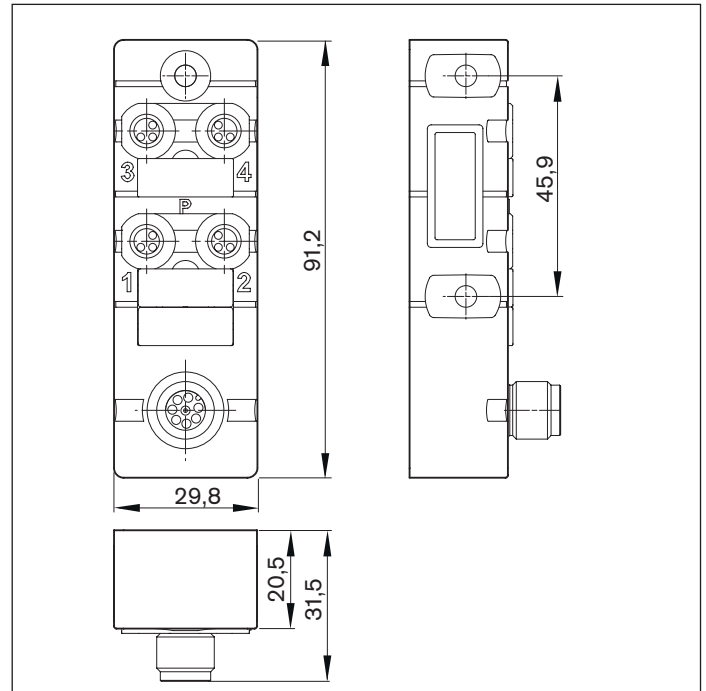
Passive distributor



Material numbers/technical data

Use	Passive distributor		
Material number	R901425737	R901429917	R911344592
Designation	8000-84070-0000000	8000-84071-0000000	
Version	straight, for 1 - 4 sensors		
Operating current per contact	max. 2 A		
Operating voltage	24 V DC		
Switching logic	PNP	NPN	
Connection type 1	4x female connector, straight, M8x1, 3-pin self-locking screw thread		For technical data and dimensional drawings, see adapter
Connection type 2	Straight plug, M12x1, 8-pin, IDC, self-locking screw thread		
Function indicator			
Operating voltage indicator			
Connection cross-section	-		
Ambient temperature	-20 °C to +70 °C		
Protection class	IP67 (inserted and screwed down)		
Certifications and approvals	  		

Accessories for passive distributors

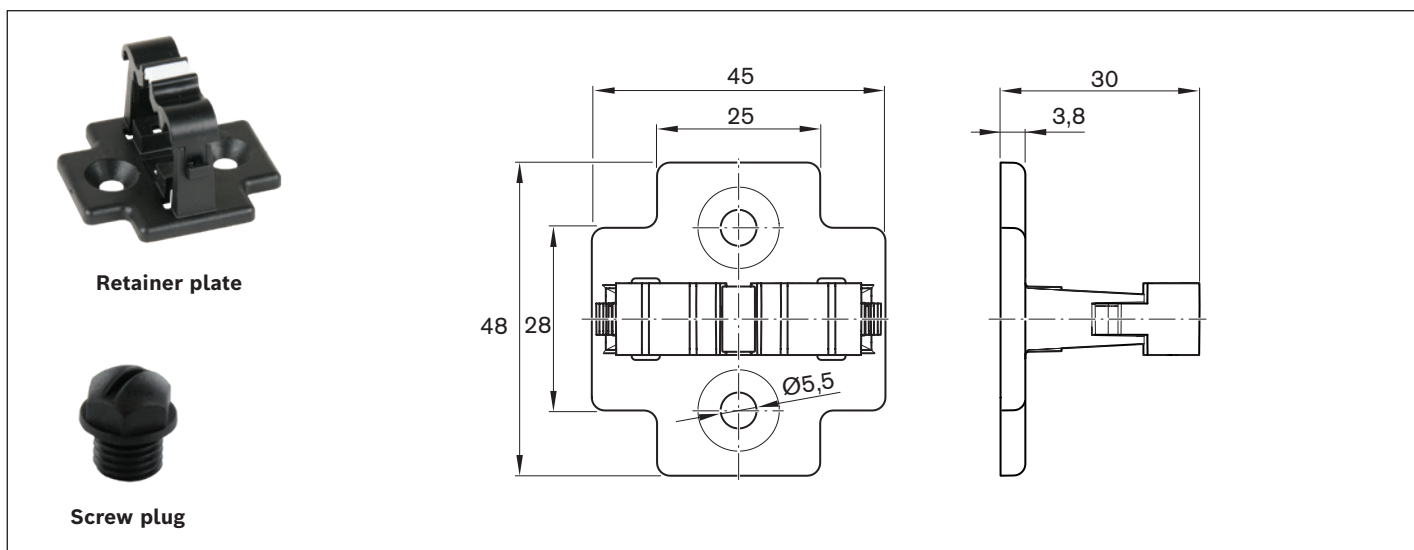

Material numbers/technical data



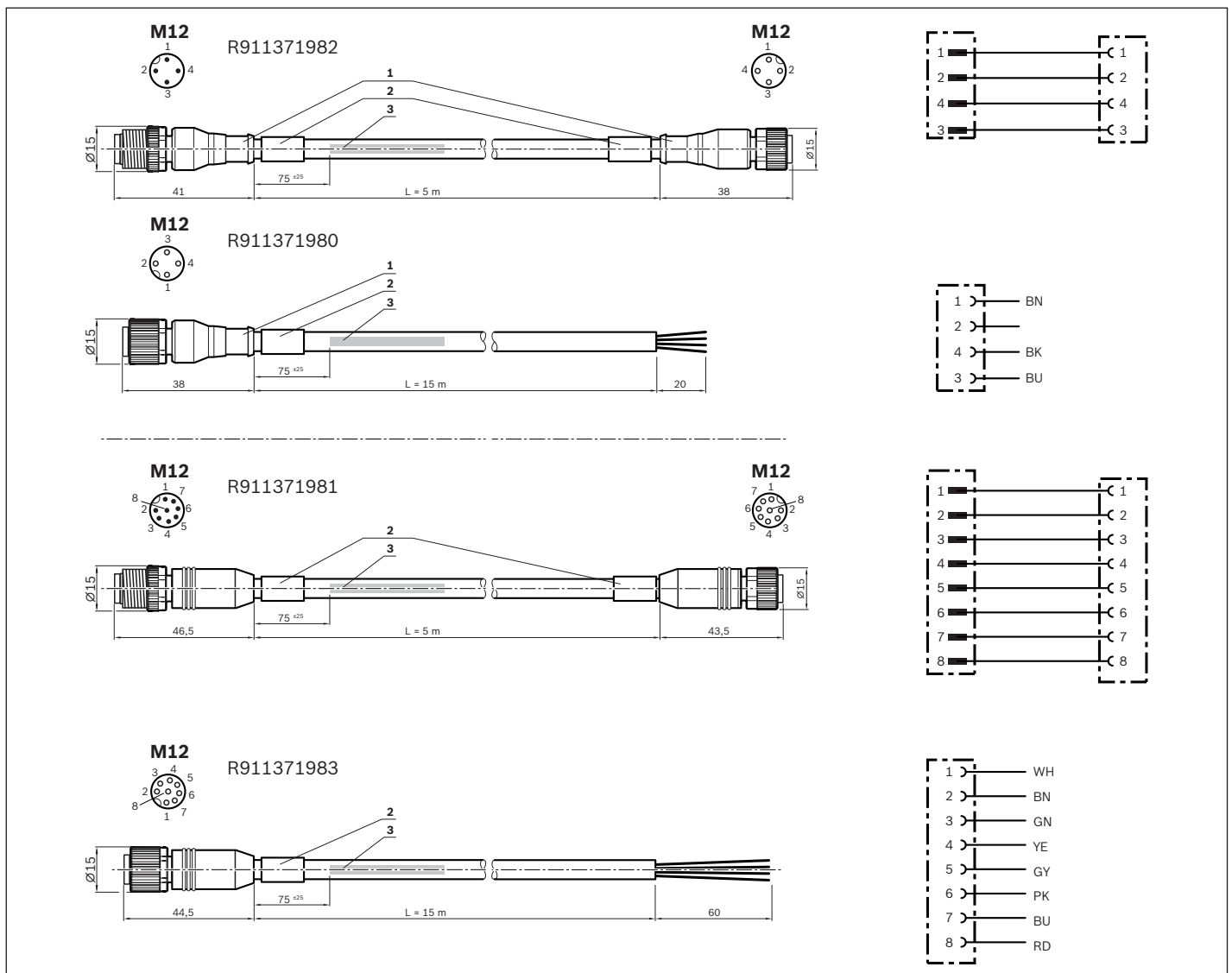
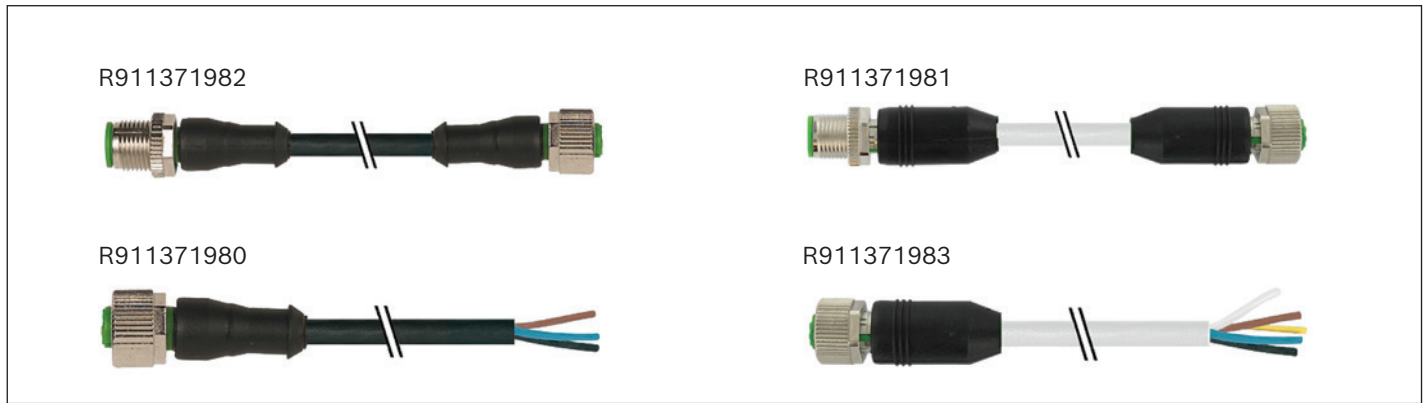

Use	For passive distributor R911344592	For passive distributors R901425737/ R901429917
Retainer plate	R913047341	-
Designation	7000-99061-0000000	-
Set	1 unit	-
Screw plug	-	R913047322
Designation	-	3858627
Set	-	10 units

Extensions for passive distributor



- 1 Contour for conduit pipe with inner diameter of 10
- 2 Cable grommet
- 3 Cable print per ordering specification 7000-08001

Material numbers/technical data

Use	Extension cable for passive distributor R911344592		Extension cable for passive distributors R901425737 / R901429917	
Material number	R911371982	R911371980	R911371981	R911371983
Designation	7000-40021-6540500	7000-12221-6541500	7000-48001-3770500	7000-17041-3771500
Length	5.0 m	15.0 m	5.0 m	15.0 m
Connection type 1	Female connector, straight, M12x1, 4-pin		Female connector, straight, M12x1, 8-pin	
Connection type 2	Male connector, straight, M12x1, 4-pin	Unassembled cable end	Male connector, straight, M12x1, 8-pin	Unassembled cable end
Function indicator	-			
Operating voltage indicator	-			
Type of cable	PUR black		PUR gray	
Operating voltage	30 V AC/DC			
Operating current per contact	max. 4 A per contact		max. 2 A per contact	
Suitable for drag chains	✓			
Torsion-resistant	✓			
Weld spark-resistant	✓			
Cable cross-section	4x0.34 mm ²		8x0.34 mm ²	
Cable diameter D	4.7 +/- 0.2 mm		6.2 +/- 0.3 mm	
Static bending radius	≥ 5 x D			
Dynamic bending radius	≥ 10 x D			
Bending cycles	> 10 mil.			
Max. permissible travel speed	3.3 m/s for 5 m travel range (typ.), up to 5 m/s for 0.9 m travel range			
Max. permissible acceleration	≤ 30 m/s ²			
Ambient temperature fixed ext.	-40 °C to +80 °C (90° max. 10,000h)			
Ambient temperature flexible ext.	-25 °C to +80 °C (90° max. 10,000h)			
Protection class	IP67 (inserted and screwed down)			
Certifications and approvals	    			

Combination examples

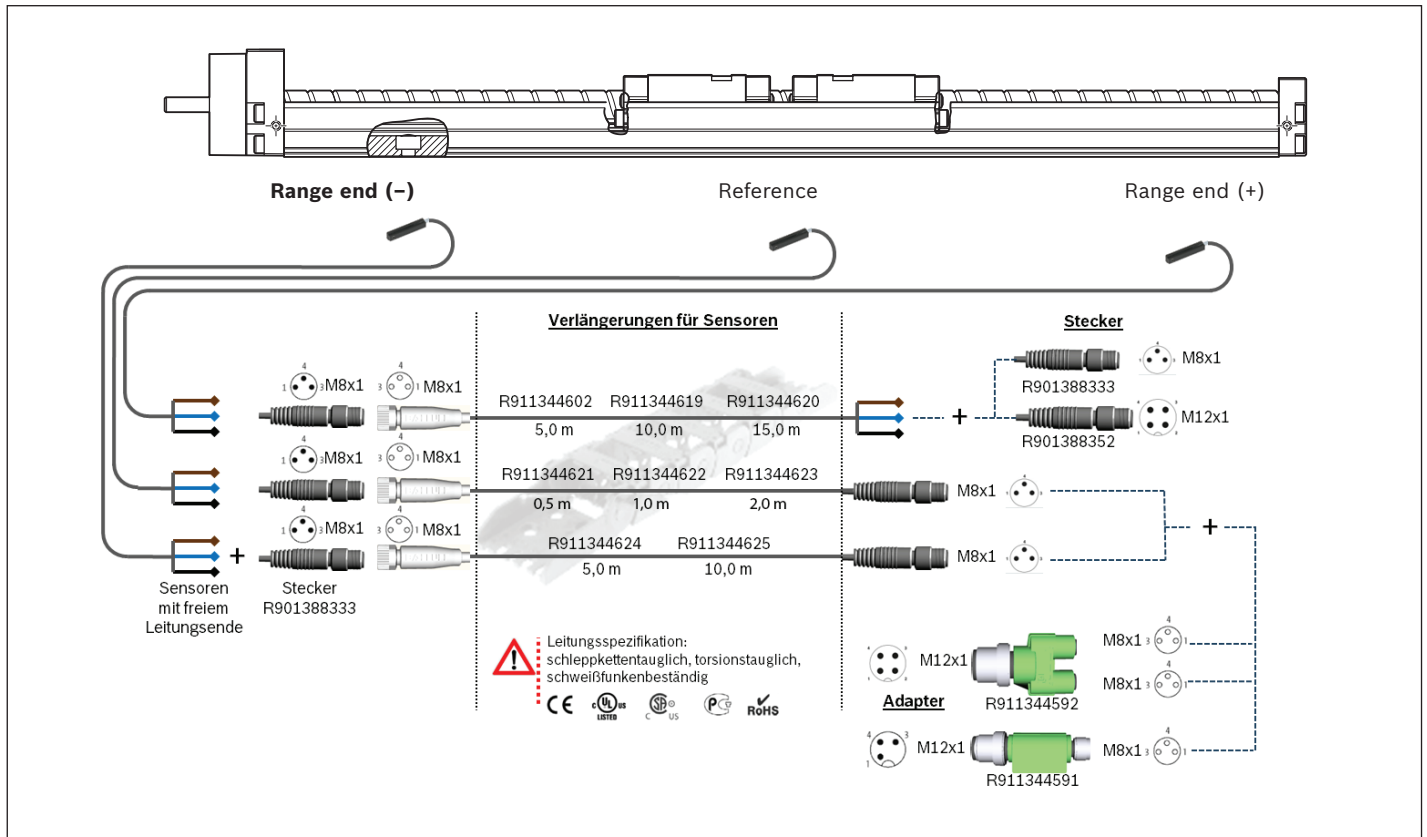

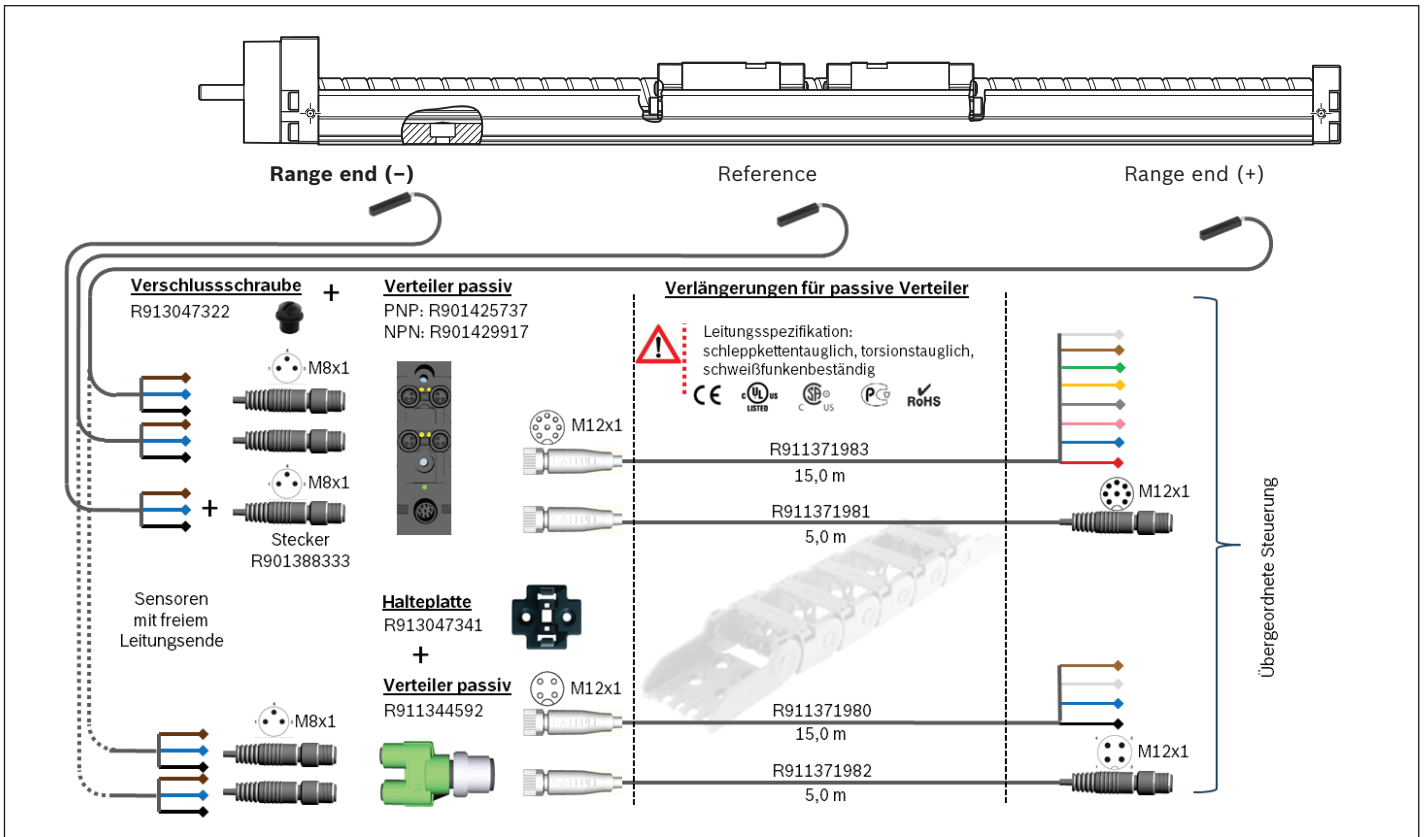

Operating conditions

Normal operating conditions

Ambient temperature with Bosch Rexroth servo motor	0 °C ... 40 °C, above 40 °C loss of performance
Ambient temperature for mechanical system (no undershooting the dew point)	-10 °C ... 60 °C
Travel range s_{\min} ¹⁾	See "Technical data" tables
Soiling	not permissible

¹⁾ Minimum travel range to ensure a reliable lubrication distribution.

Notes

For more information about intended use and safety, see "Safety instructions for linear motion systems R320103152".

For information on mounting/commissioning, see "Manual for precision modules R320103170".

PDF files of these documents can be found on the Internet at:
www.boschrexroth.com/mediadirectory

Parameterization (commissioning)

The nameplate contains reference information on the production of the linear motion system as well as technical commissioning parameters.

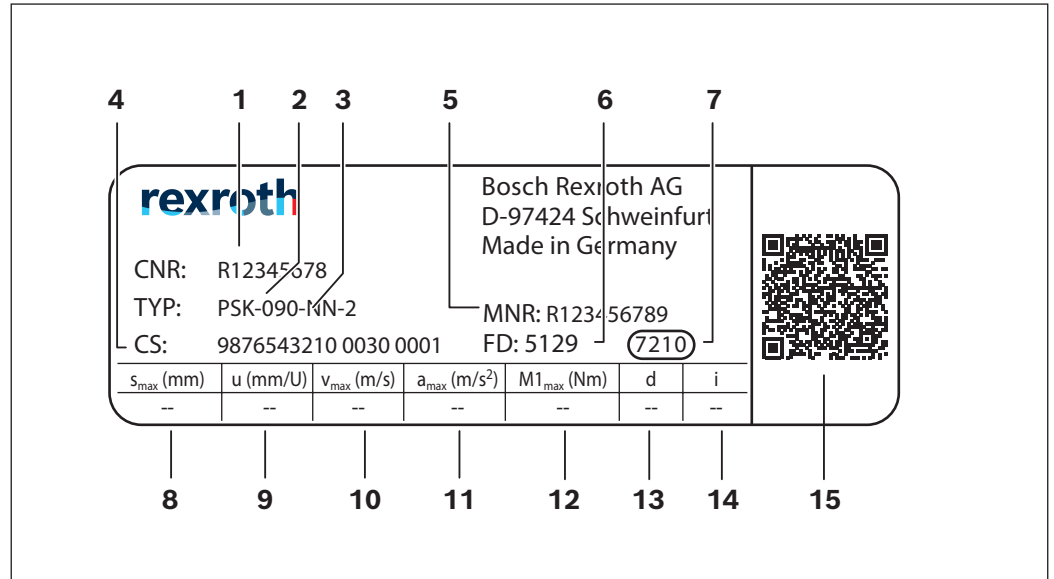

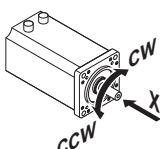
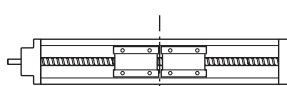
1	CNR	Customer's material number
2	TYP	Short product name
3	090	Size
4	CS	Customer information
5	MNR	Material number
6	FD	Date of manufacture
7	7210	Manufacturing location
8	s_{\max}	Maximum travel range
9	u	Feed constant without motor attachment
10	v_{\max}	Maximum speed
11	a_{\max}	Maximum acceleration rate
12	$M1_{\max}$	Maximum drive torque at motor journal
13	d	Direction of motor rotation to travel in positive (+) direction CW = clockwise CCW = counterclockwise
		 
14	i	Gear ratio
15		QR code

Fastening

► **Do not mount or support the precision module by the end blocks! The frame is the load-bearing part!**

Precision modules can be mounted using screws through drill holes in the frame.

When mounting the precision modules, please note the maximum tightening torques listed in the table.

The reference edge on the frame makes it easier to align the precision module.

Remove any cover plate before mounting the module.

For connecting dimensions, see the relevant dimensional drawings.

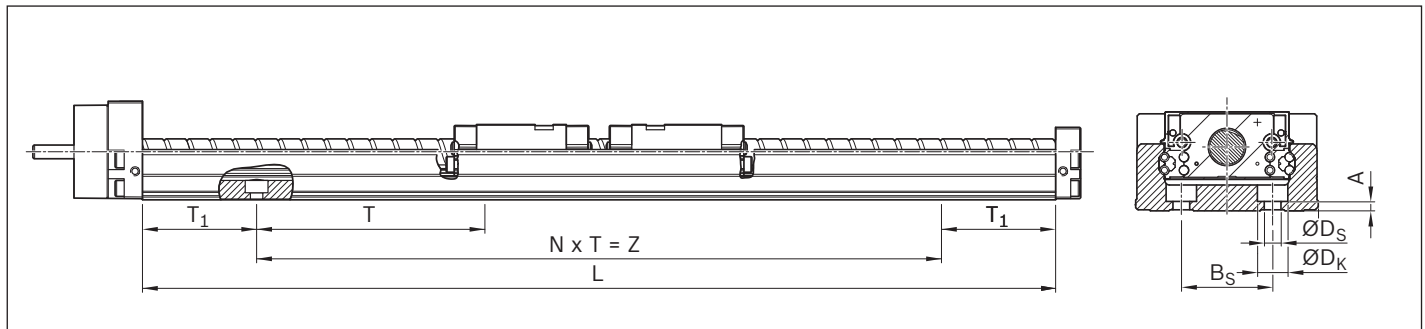
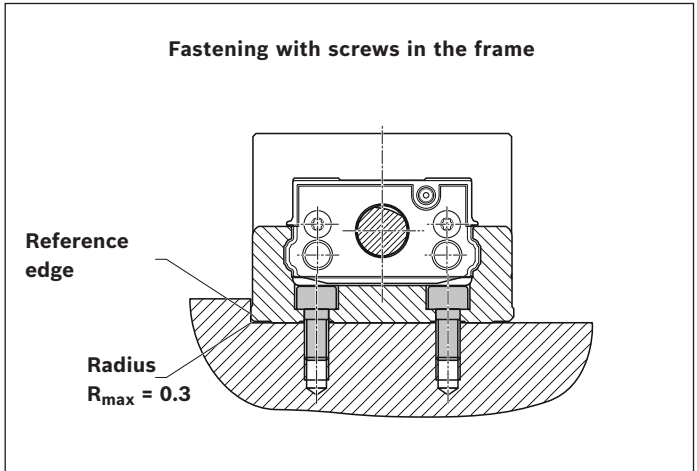

PSK-050

Dimensions (mm)									
L	A	B _s	ØD _k	ØD _s	T	T ₁	Z	N	
100	2.5	25	8	4.5	80	10	80	1	M4
150						35	80	1	
200						20	160	2	
250						45	160	2	
300						30	240	3	
350						15	320	4	
400						40	320	4	
500						50	400	5	
600						20	560	7	

PSK-060

Dimensions (mm)									
L	A	B _s	ØD _k	ØD _s	T	T ₁	Z	N	
150	3.1	30	10	5.5	100	25	100	1	M5
200						50	100	1	
250						25	200	2	
300						50	200	2	
400						50	300	3	
500						50	400	4	
600						50	500	5	
700						50	600	6	
800						50	700	7	

PSK-090

Dimensions (mm)									
L	A	B _s	ØD _k	ØD _s	T	T ₁	Z	N	
340	4.5	46	11	6.5	100	70	200	2	M6
440							300	3	
540							400	4	
640							500	5	
740							600	6	
840							700	7	
940							800	8	

Lubrication and maintenance

General notes

The lubrication of the precision modules is designed for grease lubrication (grease gun). The lube connection supplies lubricant to both the guideway and the ball screw assembly. If the module has two carriages, both of these must be lubricated.

Replacing the lube connection with a connector reduces the maximum travel range per lube connection due to the additional interference contour.

Reduction of maximum travel range

PSK	Dimensions (mm)	
	straight	Elbow connection
-050	-8.0	-11.0
-060	-7.5	-10.5
-090	-6.8	-9.8

Funnel-type lube nipple (PSK-050)

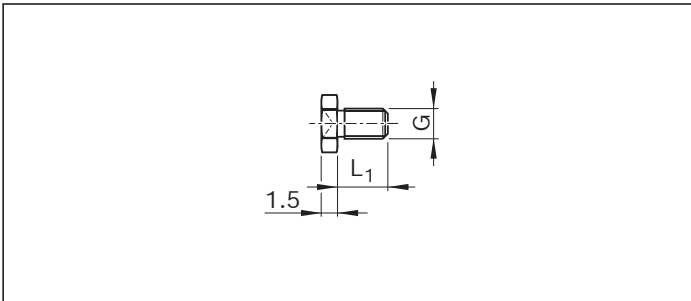

Material number	Dimensions (mm)		Mass (g)
	G	L ₁	
R3417 069 09	M4	5	0.4

Straight connectors¹⁾ for plastic tubes and metal pipes

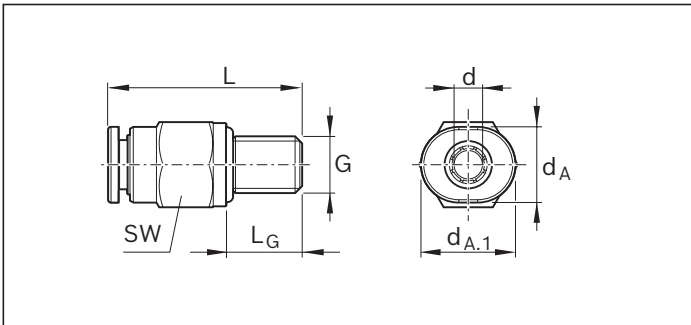

Material number	Dimensions (mm)							Mass (g)
	d _A	d _{A.1}	d±0.1	G	L	L _G	SW	
R3417 071 09	6.0	7	3	M4	16	5	6 ²⁾	1.4

¹⁾ Max. lubrication pressure: 30 bar (exerting slow pressure with manual grease gun)

²⁾ Max. tightening torque: M_A = 0.5 Nm

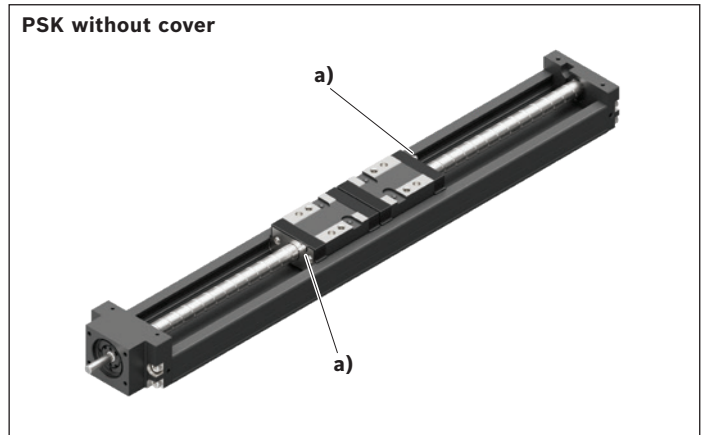

a) Lube connection

Ball-type lube nipple (PSK-060 and PSK-090)

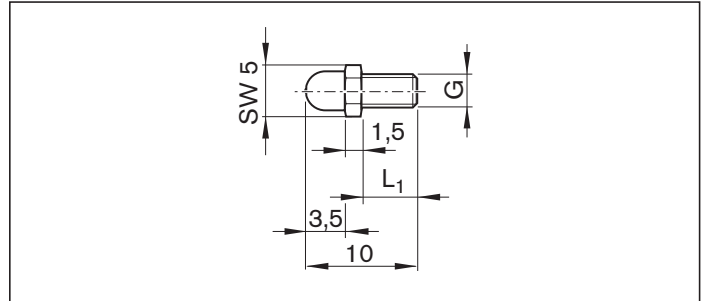

Material number	Dimensions (mm)		Mass (g)
	G	L ₁	
R3417 006 01	M4	5	0.5

Elbow plug-in connections rotatable¹⁾ for plastic tubes and metal pipes

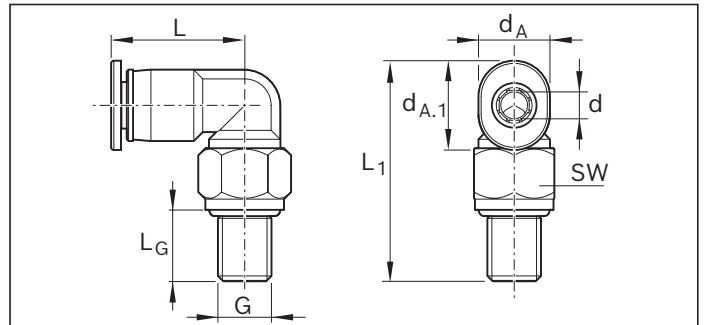

Material number	Dimensions (mm)							Mass (g)	
	d _A	d _{A.1}	d±0.1	G	L	L ₁	L _G		
R3417 072 09	6.0	7	3	M4	11	19	5	6 ²⁾	1.7

Lubricants

Lubrication version	LSS		LPG	
Basic lubrication	Dynalub 510	Dynalub 520	Preserved, basic lubrication required (see instructions)	
Size: BASA d ₀ xP	PSK-050: 8x2.5; 8x5 PSK-060: 12x5; 12x10 PSK-090	PSK-050: 8x1; 8x2 PSK-060: 12x2	PSK-050: 8x2.5; 8x5 PSK-060: 12x5; 12x10 PSK-090	PSK-050: 8x1; 8x2 PSK-060: 12x2
Consistency class	NLGI 2 (DIN 51818)	NLGI 00 (DIN 51818)	-	
Marking	KP2K-20 (DIN 51825)	GP00K-20 (DIN 51826)	-	
Lubrication with grease gun	yes		yes	
Prepared for connection to central lubrication systems	-		-	
Recommended lubricants	Dynalub 510 (grease lubricant) (NLGI2 DIN 51818)	Dynalub 520 (liquid grease) (NLGI00 DIN 51818)	Dynalub 510 (grease lubricant) (NLGI2 DIN 51818)	Dynalub 520 (liquid grease) (NLGI00 DIN 51818)
	Tribol GR 100-2 PD (grease lubricant) (NLGI2 DIN 51818)	Tribol GR 100-00 PD (liquid grease) (NLGI00 DIN 51818)	Tribol GR 100-2 PD (grease lubricant) (NLGI2 DIN 51818)	Tribol GR 100-00 PD (liquid grease) (NLGI00 DIN 51818)
Features	Good water resistance Corrosion protection Temperature range: -20 to +80 °C		Good water resistance Corrosion protection Temperature range: -20 to +80 °C	
Alternative lubricants	Tribol GR 100-2 PD Elkalub GLS 135/N2	Tribol GR 100-00 PD Elkalub GLS 135/N00	Tribol GR 100-2 PD Elkalub GLS 135/N2 Tribol GR 100-00 PD Elkalub GLS 135/N00 Dynalub 520	Tribol GR 100-00 PD Elkalub GLS 135/N00
Alternative lubricants with H1 approval	-		Berulub FG H2 SL Cassida Grease EPS2 VP 874	Berulub FB 34-00 Elkalub GLS 367/N00

► Pay attention to the notes on lubrication ⇒ Instruction

Lubricant	Availability	400 g cartridge	5 kg bucket	25 kg hobbock
Dynalub 510	Europe	R3416 037 00	-	R3416 035 00
Dynalub 520	Europe	R3416 043 00	R3416 042 00	-
Tribol GR 100-2 PD	World	R3416 031 00	-	-
Tribol GR 100-00 PD	World	R3416 032 00	-	-

	LCF	LSC	
	Dynalub 520	Castrol Tribol GR 100-2 PD	Castrol Tribol GR 100-00 PD
	PSK-050, -060, -090	PSK-050: 8x2.5; 8x5 PSK-060: 12x5; 12x10 PSK-090	PSK-050: 8x1; 8x2 PSK-060: 12x2
	NLGI 00 (DIN51818)	NLGI 2 (DIN 51818)	NLGI 00 (DIN51818)
	GP00K-20 (DIN 51826)	KP2K-20 (DIN 51825)	GP00K-20 (DIN 51826)
	-	yes	
	only via single-line piston distributor system smallest permissible piston distributor size: 0.1 cm ³	-	
	Dynalub 520 (liquid grease) (NLGI00 DIN 51818)	Tribol GR 100-2 PD (Grease lubricant) (NLGI2 DIN 51818)	Tribol GR 100-00 PD (Liquid grease) (NLGI00 DIN 51818)
	Tribol GR 100-00 PD (liquid grease) (NLGI00 DIN 51818)		
	Good water resistance Corrosion protection Temperature range: -20 to +80 °C	Good water resistance Corrosion protection Temperature range: -35 to +140 °C	
	Tribol GR 100-00 PD Elkalub GLS 135/N00	Elkalub GLS 135/N2 Dynalub 510 Castrol Tribol GR 215-2 PD	Elkalub GLS 135/N00 Dynalub 520
	-	-	

Documentation

Standard report Option 001

The standard report serves to confirm that the checks listed in the report have been carried out and that the measured values lie within the permissible tolerances.

Checks listed in the standard report:

- Functional checks of mechanical components
- Functional checks of electrical components
- Design as per order confirmation

Measurement of friction torque of complete system Option 002

The friction torque M_{Rs} is measured along the entire travel range.

- 1) Advance
- 2) Return

Example graphs

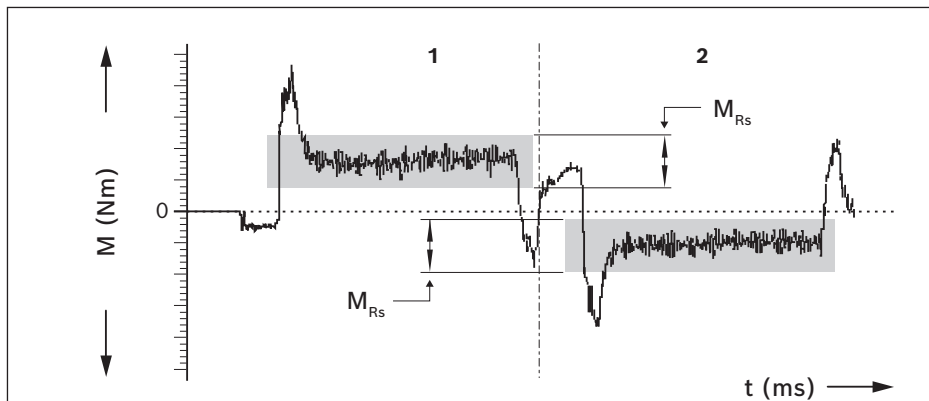

Lead deviation of screw drive Option 003

A measurement report of the deviation d over the measured travel s (see figure) is provided in table form in addition to the graph.

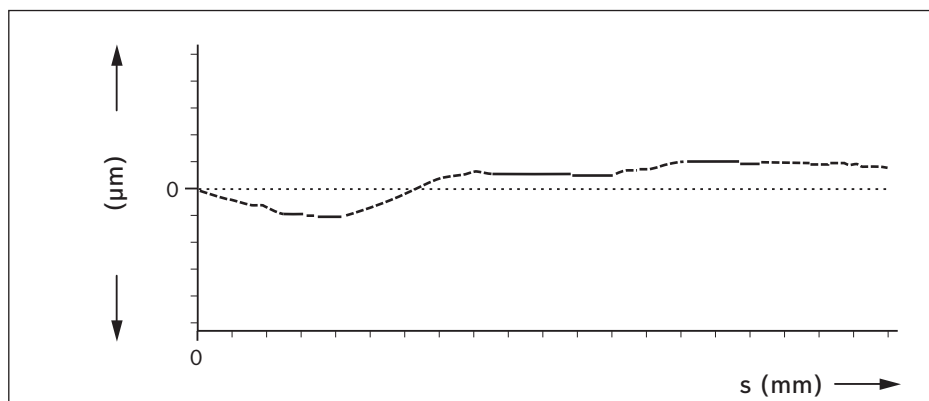

Travel accuracy Option 004

Yawing

Yawing is the angular deviation about the vertical axis. This angular deviation is converted to a linear deviation d in mm on the basis of a base length and is plotted on the graph. The base length is specified in the diagram.

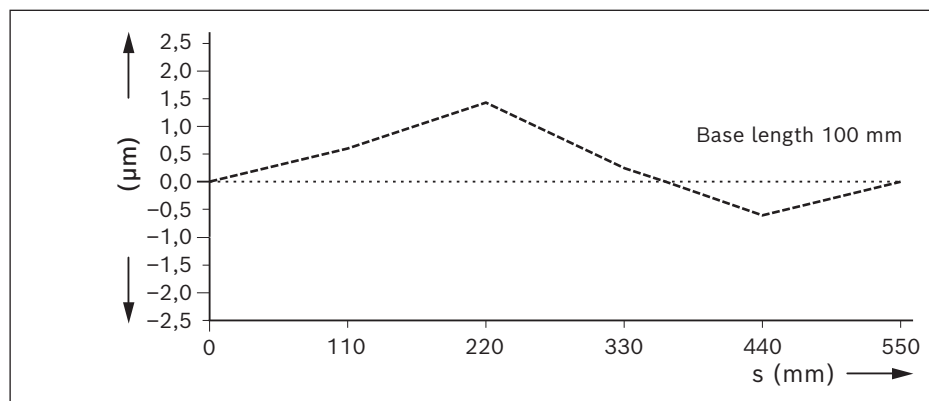
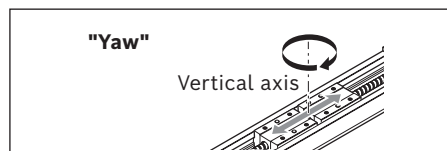

Several measuring points are passed in the course of the total travel range. The yawing and pitching deviations are measured at these points. Note The dimensions are taken with the module screwed down and assuming an ideally flat clamping surface.

Travel accuracy Option 004 (continued)

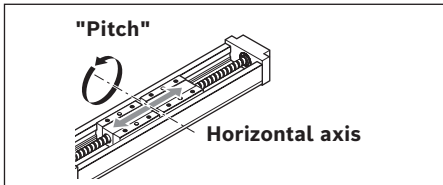

Pitching

Pitching means is the angular deviation about the horizontal axis.

This angular deviation is converted to a linear deviation δ in μm on the basis of a base length and is plotted on the graph.

Example graphs

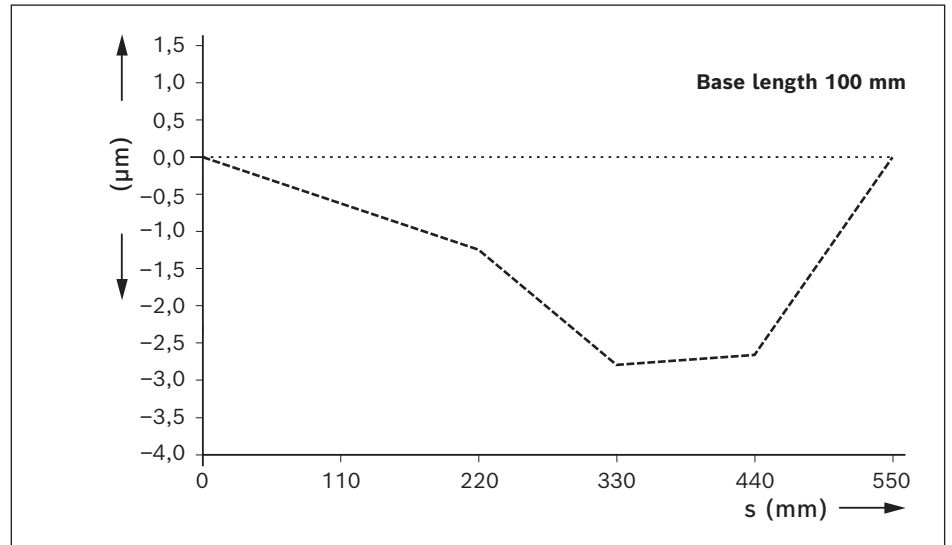

Positioning accuracy to VDI/DGQ 3441 Option 005

Measurement points are selected at irregular intervals along the travel range. This enables even periodical deviations δ in mm to be detected during positioning.

Each measurement point is approached several times from both sides.

This provides the following parameters.

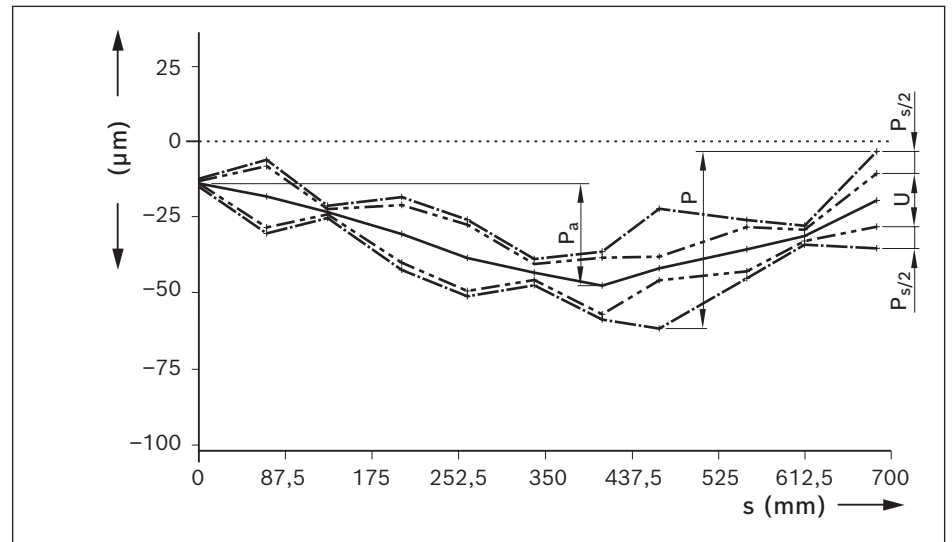

Positional uncertainty P

Positional uncertainty is a parameter for the positioning accuracy and corresponds to the total deviation. It encompasses all the systematic and random deviations in relation to positioning. Positional uncertainty takes the following characteristic values into consideration:

Position deviation P_a

The position deviation equals the maximum difference arising between the mean values of all the measurement points. It describes systematic deviations.

Reversal range U

The reversal range corresponds to the difference in mean values of the two approach directions. The reversal range is determined at every measurement point. It describes systematic deviations.

Position variation range P_s

The position variation range describes the effects of random deviations. It is determined at every measurement point.

Ordering example for PSK-090

Ordering data		Explanation
Precision module	PSK-090-NN-2	Precision module PSK-090-NN-2
Accuracy class	P	Precision class
Length	540	Precision module length L = 540 mm
Reference edge	R	Right side reference edge
Lubrication	LSS	Lubrication version LSS
Cover	0	Without cover
Drive	16x10	Ball screw assembly BASA 16x10
Carriage		
Length	S	Carriage length, standard
Quantity	1	One carriage
Carriage centerline-to-centerline distance L _w ¹⁾	-	-
Version	F001	With flange and coupling
Mounting interface		
Gear ratio	i = 1	Gear ratio i = 1
Mechanical interface	MS2N03-D	Motor attachment
Motor		
Motor code	MS2N03-D0BYN	Motor type
Connection	1	Motor connection (1 cable)
Brake	Y	With brake
Motor connector position	090	Motor connector position = 90°
Switching system		
Sensor 1	120	PNP NC
Sensor 2	120	PNP NC
Sensor 3	120	PNP NC
Sensor mounting	001	With cable duct, with switching cam
Documentation	001	Standard report

¹⁾ Only required for two carriages

Inquiry/order form

Ordering data		Customer information
Precision module		
Accuracy class		
Length		
Reference edge		
Lubrication		
Cover		
Drive		
Carriage		
Length		
Quantity		
Carriage centerline-to-centerline distance L_w ¹⁾		
Version		
Mounting interface		
Gear ratio		
Mechanical interface		
Motor		
Motor code		
Connection		
Brake		
Motor connector position		
Switching system		
Sensor 1		
Sensor 2		
Sensor 3		
Sensor mounting		
Documentation	001	Standard report

¹⁾ Only required for two carriages

²⁾ The motor geometry code is required for motors according to customer specifications

Motor attachment kits according to customer specification (motor geometry code)

The dimensions queried result in a unique "motor geometry code":

	□□ - □□ - □□□ - □□□ - □□□ - M □□ - □□□ - □□□
∅D = Shaft diameter	□□
C = Shaft length	□□
∅E = Centering diameter	□□□
C₁ = Centering depth	□□□
∅F = Pitch diameter	□□□
∅G = Drill hole for fastening screw (specify thread diameter)	□□□
B₁ = Flange thickness	□□□
A = Flange edge dimension	□□□

Quantity Order of: _____ unit(s), _____ per month, _____ per year, per order, or _____
 Comments: _____

From	
Company	Name
Address	Department
	Phone
	E-mail address

Further information

Bosch Rexroth Linear Motion Technology homepage

<https://www.boschrexroth.com/en/xc/products/product-groups/linear-motion-technology/index>

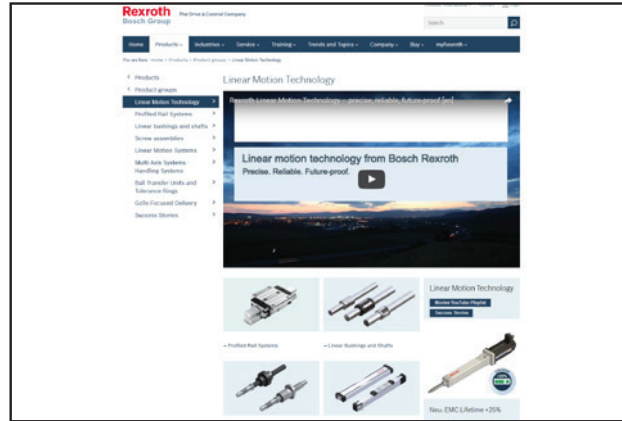

Homepage Linear Axes

<https://www.boschrexroth.com/en/gb/products/product-groups/linear-motion-technology/topics/linear-axes/>

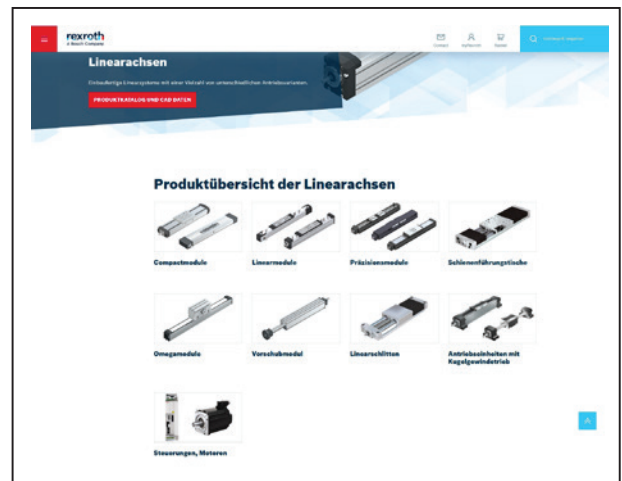

Configurators and tools

<https://www.boschrexroth.com/en/xc/products/engineering/econfigurators-and-tools/econfigurators>

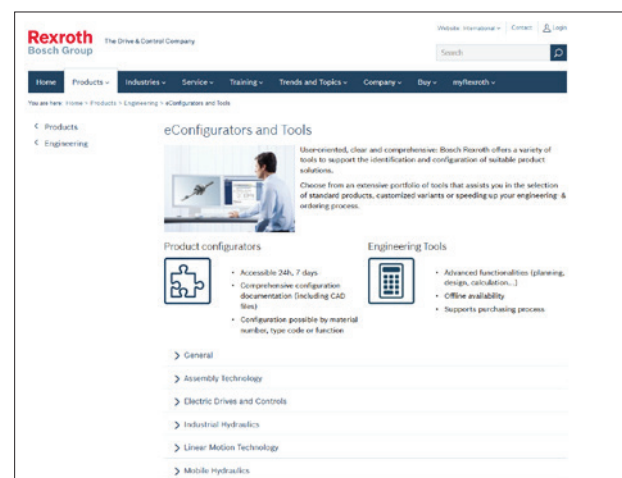
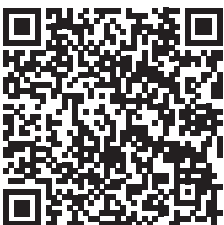

Abbreviations

Abbreviations for linear motion systems

Abbreviation/ index	Designation	Unit
a	Acceleration	(m/s ²)
a_{max}	Maximum acceleration rate	(m/s ²)
BASA	Ball screw assembly	(–)
B_t	Belt type	(–)
c_{spe}	Specific spring rate	(N)
C_{gw}	Dynamic load capacity, guideway	(N)
C_{bs}	Dynamic load capacity, ball screw assembly	(N)
C_{fb}	Dynamic load capacity, fixed bearing	(N)
d₀	Nominal diameter, ball screw assembly	(mm)
d₃	Belt pulley diameter	(mm)
f_w	Load factor	(–)
F₁, F₂, ... F_n	Axial load during phases 1 ... n	(N)
F_{bp}	Max. belt drive transmission force	(N)
F_{comb}	Combined equivalent bearing load	(N)
F_m	Equivalent dynamic axial load	(N)
F_{pr}	Preload force on motor	(N)
F_{t zul}	Belt elasticity limit	(N)
F_y	Load due to a resulting force in the y-direction	(N)
F_{y max}	Maximum dynamic load in y-direction	(N)
F_z	Load due to a resulting force in the z-direction	(N)
F_{z max}	Maximum dynamic load in z-direction	(N)
g	Gravitational acceleration (= 9.81)	(m/s ²)
i	Gear ratio	(–)
I_y	Planar moment of inertia about the y-axis	
I_z	Planar moment of inertia about the z-axis	
J_{br}	Mass moment of inertia of the motor brake	(kg/m ²)
J_c	Mass moment of inertia of the coupling	(kg/m ²)
J_{dc}	Mass moment of inertia of the drive train	(kg/m ²)
J_{ex}	Mass moment of inertia of the mechanical system	(kg/m ²)
J_{ge}	Mass moment of inertia of the gear about the motor journal	(kg/m ²)
J_m	Mass moment of inertia of the motor	(kg/m ²)
J_s	Mass moment of inertia of the linear motion system	(kg/m ²)
J_{sd}	Mass moment of inertia of the belt side drive about the motor journal	(kg/m ²)
J_t	Translative mass moment of inertia of the external load based on the linear motion system screw journal	(kg/m ²)
k_{g fix}	Constant for fixed portion of mass	(kg)
k_{g var}	Constant for variable-length portion of mass	(kg/mm)

Abbreviation/ index	Designation	Unit
k_{J fix}	Constant for fixed portion of mass moment of inertia	(kg/mm ²)
k_{J m}	Constant for mass-specific portion of mass moment of inertia	(mm ²)
k_{J var}	Constant for variable-length portion of mass moment of inertia	(kg/mm)
L	Length of the linear motion system	(mm)
L	Nominal service life – in revolutions – in meters	(min ⁻¹) (m)
L_{ad}	Additional length	(mm)
L_{ca}	Carriage length	(mm)
L_h	Nominal service life	(h)
L_m	Length of the motor	(mm)
L_{max}	Max. length	(mm)
L_w	Centerline-to-centerline distance between carriages	(mm)
m_{br}	Mass of the brake	(kg)
m_{ca}	Moved mass of system of carriage	(kg)
m_{ex}	Moved external load	(kg)
m_{fc}	Mass of flange and coupling	(kg)
m_m	Mass of the motor	(kg)
m_s	Mass of the linear system (without attachments)	(kg)
m_{sd}	Mass of the timing belt side drive	(kg)
M₀	Continuous motor torque	(Nm)
M_{cN}	Rated torque of coupling	(Nm)
M_g	Weight moment at motor journal	(Nm)
M_{ge}	Maximum permissible acceleration torque of the gear (at the output drive)	(Nm)
M_L	Dynamic longitudinal moment load capacity	(Nm)
M_m	Equivalent dynamic torque	(Nm)
M_{max}	Max. possible motor torque	(Nm)
M_{mech}	Maximum permissible drive torque for mechanical system	(Nm)
M_p	Maximum permissible drive torque (at drive journal)	(Nm)
M_R	Friction torque at motor journal	(Nm)
M_{Rge}	Friction torque of gear at motor journal	(Nm)
M_{Rs}	Friction torque of system	(Nm)
M_{Rsd}	Friction torque of belt side drive at motor journal	(Nm)
M_{sd}	Maximum permissible drive torque of the belt side drive	(Nm)
M_{stat}	Static load moment	(Nm)
M_t	Dynamic torsional moment load capacity	(Nm)
M_x	Dynamic torsional moment around the x-axis	(Nm)

Abbreviations for linear motion systems (continued)

Abbreviation/ index	Designation	Unit
$M_{x \max}$	Maximum permissible torsional moment around the x-axis	(Nm)
M_y	Dynamic torsional moment around the y-axis	(Nm)
$M_{y \max}$	Maximum permissible torsional moment around the y-axis	(Nm)
M_z	Dynamic torsional moment around the z-axis	(Nm)
$M_{z \max}$	Maximum permissible torsional moment around the z-axis	(Nm)
n_1, n_2, \dots, n_n	Rotary speed in acceleration and braking phases	(min^{-1})
$n_{A1 \dots n}$	Starting speed in phase 1 ... n	(min^{-1})
$n_{E1 \dots n}$	Ending speed in phase 1 ... n	(min^{-1})
n_{ge}	Maximum permissible rotary speed of the gear	(min^{-1})
n_m	Average rotary speed	(min^{-1})
n_{mech}	Maximum permissible rotary speed for mechanical system	(min^{-1})
n_{max}	Max. motor speed	(min^{-1})
n_p	Maximum permissible rotary speed of the linear motion system	(min^{-1})
P	Screw lead	(mm)
P_{app}	Effective power in application	(W)
Keyway	Keyway	(–)
s_a	Acceleration travel	(mm)
s_e	Excess travel (excess travel s_e should be greater than braking distance. The acceleration travel can be assumed as the reference value for the braking distance.)	(mm)
s_{eff}	Effective stroke	(mm)
s_{min}	Minimum travel range	(mm)
s_{max}	Maximum travel range	(mm)
SPU	Screw support	
t_a	Acceleration/braking time	(s)
t_1, t_2, \dots, t_n	Time for phase 1 ... n	(s)
u	Feed constant	(mm/rev)
v_1, v_2, \dots, v_n	Speed in phase 1 ... n	(m/s)
v_{max}	Maximum permissible speed	(m/s)
v_{mech}	Maximum permissible speed of mechanical system	(m/s)
v_m	Average linear speed	(m/s)
V	Ratio of mass moments of inertia of drive chain and motor	(–)
z_1	Application point of the effective force	(mm)
π	Kreiszahl	(–)

Bosch Rexroth AG

Ernst-Sachs-Straße 100
97424 Schweinfurt, Germany
Tel. +49 9721 937-0
Fax +49 9721 937-275
www.boschrexroth.com

Find your local contact person here:

www.boschrexroth.com/contact

